

b10852359

Φ10110884

118903202

**SUBCATEGORIZATION PROPERTIES  
OF  
TSWANA VERBS**

BY

LTIO  
DITA

**SHOADI EZEKIEL DITAUNYANE**

SUBMITTED IN PART FULFILLMENT OF THE REQUIREMENTS  
FOR THE  
DEGREE OF  
MAGISTER ARTIUM  
IN THE DEPARTMENT OF  
AFRICAN LANGUAGES  
AT  
VISTA UNIVERSITY

**SUPERVISOR: PROF. B.T. KHOALI**

JANUARY 1996  
BLOEMFONTEIN



\*04020772\*

## ACKNOWLEDGEMENTS

- Firstly, I direct my deepest gratitude to God the Almighty who made it possible for me to write this thesis.
- My sincere thanks to Prof. B.T. Khoali, my supervisor and lecturer, for his forbearance, his constructive and positive criticism as well as his guidance in the writing of this script.
- I would also like to thank Ms. Anita Mans for the professional manner in which she typed this script.
- Finally, my deepest word of gratitude goes out to my loving wife Setshego Mercy for acting as my Tswana consultant (and unbelievably so), for giving me moral support when I needed it the most and for allowing me all the time I needed for my studies.
- Thanks to all my friends for their inspiration.

Pulai Barolong.

## DECLARATION

I declare that :

### SUBCATEGORIZATION PROPERTIES OF TSWANA VERBS

is my own work, that all the sources used or quoted have been indicated and acknowledged by means of complete references, and that this dissertation was not previously submitted by me for a degree at another university.

## SUMMARY

Subcategorization properties of Tswana verbs by:

SHOADI EZEKIEL DITAUNYANE  
MAGISTER ARTIUM  
DEPARTMENT OF AFRICAN LANGUAGES  
SUPERVISOR: PROF. B.T. KHOALI

In this dissertation I discuss subcategorization properties of Tswana verbs. I give specific attention to various types of complements which follow a basic verb in a sentence. In short, I analyze the verb-object asymmetrical in a typical Tswana sentence, i.e. a subject-verb-object sentence.

In Chapter 1 I introduce my topic in terms of the aim and theoretical assumptions embraced in this thesis. I intend to prove that verbs differ according to their complements. In the same chapter I allude to the fact that verbal extensions can be added within a verbal-structure to change its argument-structure. The Government and Binding Theory is my yardstick.

In Chapter 2 I give special attention to the morphology of basic verbs, i.e. by unpacking the structure of each verb it will be demonstrated that some morphemes within the verb structure have a syntactic significance. I illustrate my point by employing all types of verbal extensions in Tswana.

In Chapter 3 I deal specifically with the different types of Tswana verbs namely the transitives, intransitives and ditransitives.

In Chapter 4 I discuss sentential complementation as well as auxiliary verbs as a peculiar type of verbal heads. Copulatives are also given attention.

# TABLE OF CONTENTS

	PAGE
<u>CHAPTER 1</u>	
1. INTRODUCTION .....	1
1.1 AIM .....	1
1.2 HYPOTHESIS .....	1
1.3 THEORETICAL ASSUMPTIONS .....	2
1.4 LITERATURE REVIEW .....	3
1.5 METHODOLOGY .....	3
 <u>CHAPTER 2</u>	
2.1 THE INTERFACE BETWEEN SYNTAX AND MORPHOLOGY .....	5
2.2 VERBAL STRUCTURE (MORPHOLOGY) .....	6
2.2.1 Basic Morphemes .....	6
2.3 SUBCATEGORIZATION .....	7
2.3.1 Transitive Verbs .....	9
2.3.1.1 Case Assignment .....	10
2.3.1.2 Theta role Assignment .....	11
2.3.2 Ditransitive Verbs .....	13
2.3.3 Intransitive Verbs .....	17
 <u>CHAPTER 3</u>	
3.1 VERBAL EXTENSIONS .....	21
3.2 ADDENDUM: THE USE OF SCHEMATIC REPRESENTATIONS ....	55
 <u>CHAPTER 4</u>	
4.1 OTHER COMPLEMENTS (SENTENTIAL COMPLEMENTATION) ...	59
4.1.1 Government .....	63
4.1.2 Sentence Embedding .....	67
4.2 AUXILIARY VERBS (STRICT SUBCATEGORIZATION) .....	69
4.3 DEFICIENT VERB FORMS .....	73
4.4 COPULATIVES .....	74
 FOOTNOTES	
CONCLUSION	
BIBLIOGRAPHY	

# **CHAPTER 1**

## **1. INTRODUCTION**

### **1.1 AIM**

In this dissertation we present a syntactic analysis of verbs in Tswana with special reference to their subcategorization properties. The term subcategorization properties means that verbs differ according to their selection of complements. Thus our attention will be focused mainly on verb-object relations as part of the basic word order formations of Tswana sentences. This is so because the Tswana language is essentially a subject-verb-object (SVO) language in terms of its basic word order formations of sentences.

### **1.2 HYPOTHESIS**

Firstly, we will argue that Tswana verbs differ according to their selection of complements, i.e. according to their subcategorization properties. In this case we will draw a line of demarcation between various types of complements, namely NP complements and clausal/sentential complements.

Secondly, we will argue that Tswana verbs can accommodate or add morphemes between the verb root and the verbal ending and that these morphemes which are traditionally referred to as verbal extensions can actually change the argument structure of verbs to which they are added. (In this case we will also illustrate the fact that extensions such as Passive extensions and Quasi-passive extensions are in actual fact absorbers of Case and this predicts that these extensions/morphemes cannot co-occur with all constituents that need case, particularly the object NPs).

Thirdly, we will argue that apart from basic verbs we also have auxiliary verbs which can function as verbal heads in sentences. Furthermore, we will also argue that these auxiliary verbs can only function in a sentence when they are used with basic verbs and that they only subcategorize for clausal/sentential complements which are grammatical and not lexical.

### 1.3 THEORETICAL ASSUMPTIONS

The Government and Binding theory is the yardstick of our discussion. We shall focus mainly on the following subsystems of this theory: Firstly, the Case theory which generally 'accounts for some of the formal properties of overt NPs and integrates the traditional notion of Case into the grammar' : (Haegeman 1992). In simple terms, it is about the assignment of Case to differently-positioned overt NPs. The Case filter is the basic component of the Case theory and it states that 'every overt NP must be assigned Abstract Case' (Chomsky 1981)

Secondly, the theta theory which is the 'component of the grammar that regulates the assignment of thematic roles', (Sells 1985). Thematic roles refer to semantic relationships between verbs and their arguments. 'An argument is part of a basic meaning which a sentence expresses (i.e. proposition) and it is in essence something which is named or talked about in a sentence', (Richards et al 1992).

The various argument structures of different sentences will be given attention in this study. The basic principle of the theta theory is the theta-criterion which states that 'each argument is assigned to one and only one theta role and each theta role is assigned to one and only one argument', (Haegeman 1992).

Thirdly, the X-bar theory which is 'an approach to syntax that attempts to show the general principles of language rather than deal with the structures of one particular language', (Richards et al 1992). The basic assumption in this subsystem is that the syntax is based on four main lexical categories viz: verbs, nouns, adjectives and prepositions, which become the heads of Phrases. To show the structure within each phrase marker of the whole sentence, constituents are marked, N, N', N"; V, V', V"; Adj, Adj', Adj"; P, P', P". The X-bar scheme is used to show the relationship between different constituents in the whole sentence.

It should be noted that other principles or subsystems of the Government and Binding theory will also be rendered useful throughout this study as we follow the thrust of the discussion.

The names: Transitive; Intransitive; Ditransitive; Verbal extensions; Copulatives and auxiliary verbs are all traditional terms and they have no linguistic bearing on this thesis except that they are used for an expository purpose.

## 1.4 LITERATURE REVIEW

The extent of research already done in African linguistics along the line of Transformational Generative Grammar (TGG) was established by means of a computer search. In search for such information we discovered the following things:

Firstly, that traditional grammarians such as Guma, Cole and Doke laid a good foundation for African linguistics in the Southern tip of Africa. They were particularly handy in exposing the basic structural elements of grammars (i.e. Particular grammars) in African languages such as Southern Sotho (Guma 1971), Zulu (Doke 1981), Tswana (Cole 1979), Northern Sotho (Louwrens 1991) and so on.

Even though Cole makes reference to the basic word-order formations of Tswana sentences namely the subject-verb-object order, he does not use the theoretical frame intended to be used in this dissertation in order to prove some of the not-so-obvious grammatical anomalies that exist in such formations e.g. the Passive formation.

Secondly, that a new wave of changes and developments in the field of linguistics (i.e. generally speaking) saw this field taking a new direction altogether. The advent of Transformational Generative Grammar finally led to a decline of interest among linguists in the traditional perceptions followed before.

Thirdly, that only a few exponents of African linguistics have attempted to apply the principles of T.G.G. in their studies particularly in the study of the Tswana language. This is the reason why I have chosen the Government and Binding theory. Among those exponents of African linguistics we count the following: Khoali (1993), Kruger (1994), (Posthumus (1994), Du Plessis et al (1992), etc.

## 1.5 METHODOLOGY

We shall use Noam Chomsky's delineation of sentence well-formedness as our technique. In this case we will test the Phonological, Syntactic, Morphological, Semantic, as well as pragmatic well-formedness of sentences in order to make our discussion valid in terms of the relevancy of sentence structures.

In this way, any sentence which is ruled out as an ill-formed sentence will be considered to be an ungrammatical sentence. Furthermore, I will use my own intuitions as a native Tswana speaker as well as the intuitions of other native Tswana speakers (friends, colleagues, etc.) to determine the well-formedness (or grammaticality) of sentences. Intuitions in this case refer to the ability to make judgements about whether or not a given sentence is well-formed. My intuitions and those of others will span Phonological, Syntactic, Morphological, Semantic, as well as pragmatic well-formedness and all of this will be done in accordance with what is dictated to us by the topic. We will use examples derived from a Tswana dialect 'Serolong' which is spoken in Mangaung, Bloemfontein.

## CHAPTER 2

### 2.1 THE INTERFACE BETWEEN SYNTAX AND MORPHOLOGY

Since the theme of our dissertation is subcategorization of verbs, there is a need to identify morphemes of verbs in general. In unpacking the structure of each verb it will be demonstrated that some morphemes within the verb structure have a syntactic significance. In short, morphemes affect the distribution of verbs in a sentence. If this conception holds (as it will be demonstrated that it does) then there is a need for a resurgence of interest in morphology as a separate branch of language study.

Ever since the advent of Transformational Generative Grammar (TGG) morphology has been incorporated into syntax. Thus, unlike Phonology, Semantics and Syntax, morphology has not been treated as an independent linguistic component within the framework of TGG. (Matthews 1989).

The importance of morphological analysis as a separate branch of language study is stressed/emphasised by Spencer (1991) when he states: 'This knowledge of word structure is in many respects of a kind with knowledge of sound structure and knowledge of sentence structure. It is part of what we have to know in order to be native speakers of English, and for that reason it is part of that knowledge of language which linguists regard as properly linguistic. **Hence, it is something which linguistic theory has to account for, in the same way that it accounts for knowledge of phonological patterns or knowledge of syntactic structures.** The branch of linguistics which concerns itself with these questions is morphology.' Emphasis added.

It is only until recently that there has been a massive reawakening in this field of study. Bauer (1992:5) corroborates this point when he writes: 'It was also progress in the study of syntax which eventually led to the realization that there were still questions to be answered in morphology. As a result there has in recent years been a resurgence of interest in morphology.'

Bauer (1992:4) draws a line of distinction between Morphology and Syntax when he writes: 'morphology ..... is a set of rules which are postulated by the linguist to account for the changing in the shapes of words.' He further defines syntax as 'a set

of rules postulated by the linguist to account for the ways in which words are strung together.'

It should also be noted that morphology has a language - specific base. Bloomfi eld (1970:207) better defines this point when he states: 'Accordingly, languages differ more in morphology than in syntax. The variety is so great that no simple scheme will classify languages as to their scheme.'

According to Kruger (1994:15) 'the overwhelming majority of Tswana words are morphologically complex. As a result of this feature it is important to identify and to classify the various types of morphological items.'

It is against the background of the evidence we gave above that we intend to give a morphological analysis of verbs before we discuss anything else pertaining to them. In doing this, we are also aware of concerns raised by Posthumus (1994) when he argues that African language linguists have opted for a root-based approach towards their morphological analysis of African languages at the expense of a stem-based (or word-based) morphology. However, it is not within the purview of this section (discussion) to discuss such philological argumentations. We will now discuss the structure of basic verbs in the following section.

## 2.2 VERBAL STRUCTURE (MORPHOLOGY)

### 2.2.1 BASIC MORPHEMES

A typical Tswana verb is formed by two basic morphemes viz:

- (a) Verbal lexical morpheme or root.
- (b) Verbal grammatical morpheme (verbal ending. VE)

These can be illustrated in examples (1) and (2) given below:

1.	Motho	o	batla	ntlo
	N	AGR	V	N
	Person	AGR	want(s)	a house

2.	Mosimane	o	rata	mosetsana
	N	AGR	V	N
	Boy	AGR	love(s)	a girl

In examples (1) and (2) above the "-batl-" in (1) and "-rat-" in (2) are verbal lexical morphemes, i.e. verbal roots. The -a after each root is the suffixal verbal grammatical morpheme or the verbal ending. It should be clear that the agreement morpheme (namely the subject concord) is not regarded as part of the verb. Sells' (1985), argues that 'There is little or no evidence of syntactic constituency of Aux (i.e. INFL) and VP. Thus INFL (or inflection node) dominates material carrying information about such things as tense, aspect, verb agreement (such as agreement morphemes) and modality in the clause. It is because of INFLVP controversies that an agreement morpheme will not be regarded as part of the verb in this study. Such controversies are, however, not part of this discussion. This is contrary to traditional analysis where the verb is assumed to be formed by the subject concord and the verb stem. (Doke 1945, Guma 1971, Cole 1979).

Thus the 'o' in (1) and (2) above does not constitute the basic morphology of a Tswana verb. In the following section I discuss the various types of basic verbs with specific reference to their subcategorization properties.

### 2.3 SUBCATEGORIZATION

A typical Tswana sentence consists out of a subject, a verb as well as an object. This implies that a verb (whether extended or not) must occur with other constituents in the formation of a sentence. The constituents that are of primary importance in this study are those that follow a verb in a sentence. These constituents vary from NPs, ADVPs, PPs, ADJPs and CPs . These constituents occur in a sentence because of the following reasons:

- (a) Because a verb demands that they should be there, i.e. a verb can only co-occur with them in a sentence.
- (b) Because they avail theta-roles to the verb.
- (c) Because they modify the verb in a sentence. (These are optional in nature).

The constituents described in points (a) and (b) above are known as complements. Constituents described in point (c) above are known as adjuncts (or modifiers). In this way, complements are those constituents which are preceded by a verb in a sentence. It is at this stage where we differentiate between complements which are essentially NP complements, i.e. a verb is followed by an object which is primarily nominal (+ N-V) (and this type of complement is the one which is described in points (a) and (b) above), and those adjuncts which are essentially descriptive in nature and these are also called modifiers (described in point (c) above).

Points (a), (b) and (c) above can be illustrated by means of examples (3) and (4) and (5) given below:

3.	Rre	o	betsa	bana
	N	AGR	V	N
	Father	AGR	beat(s)	children

4.	Malome	oa	tsamaya
	N	AGR	V
	Uncle	is	going (walking)

5.	Malome	o	tsamaya	thata
	N	AGR	V	ADV
	Uncle	AGR	walk(s)	too much

Example (3) above presupposes the need for an NP object at the end of a sentence in this case the noun bana. Thus, if NP is missing in example (6) below:

6.	*	Rre	o	betsa
		N	AGR	V
		Father	AGR	beat(s)

then such a sentence as example (6) above is ill-formed. In example (4) above the verb tsamaya does not presuppose the need for an NP complement. In this way, example (4) remains syntactically, semantically and pragmatically well-formed

(Radford 1988). It is evident therefore that the adverb *thata* in example (5) above can optionally co-occur with the verb *tsamaya* and it serves the function of describing a verb in the sentence.

The X-bar theory predicts that if a constituent behaves like the complement 'bana' in (3) above then it should be daughter to bar-one (on the X-bar scheme). Whereas if it behaves like the modifier 'thata' as in example (5) above then it should be sister to bar-one because it shares the same mother node with bar-one. In other words, there are verbal roots which need complements and others which do not.

Bar-two on the X-bar scheme is the maximal projection and bar-one is the intermediate projection. The X-bar scheme is illustrated in example (7) below:

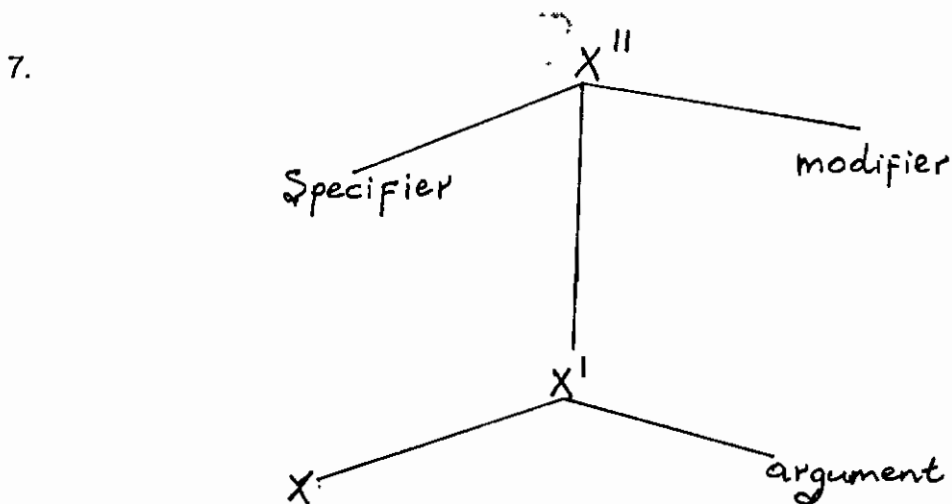

The following discussion is about verbs or verb roots which need complements and those that do not.

### 2.3.1 TRANSITIVE VERBS

Transitive verbs are those verbs which presuppose the need for an object NP i.e. they take an object. This predicts that such verbs occur in sentences that are essentially SVO sentences e.g. as in (8) below:

8.	Bana	ba	tshela	nóka
	N	AGR	V	N
	Children	AGR	cross	river
	S		V	O

Verbs which subcategorize for object NPs also theta-mark and Case-mark positions for which they subcategorize. On the one hand, this means that they assign theta-roles to object NPs and on the other hand, they assign accusative Case to object NPs.

(Sells 1985). Transitive verbs are therefore both Case and theta-role assigners (the accepted notation for theta-role is  $\Theta$ -role). For a moment we will focus on the assignment of Case and later  $\Theta$ -role assignment.

### 2.3.1.1 CASE ASSIGNMENT

In a syntactic string the subject NP will always get Case (nominative) from INFL and object NP will obtain Case (accusative) from verbs. Consider the following example:

9.	Mpho	o	betsa	ngwana
	N	AGR	V	N
	Mpho	AGR	beat(s)	a child

In example (9) above the object NP *ngwana* obtains its Case from the verb *betsa* whereas the subject NP *Mpho* obtains its Case (nominative) from INFL. Case assignment takes place in the d-structure and it also takes place under subjacency i.e. the object NP should always follow the verb immediately in a sentence. If this is not the case, ungrammatical sentences are yielded. Consider example (10) that follows below:

10.	*	Setshego	o	apara	thata	kobo
		N	AGR	V	ADV	N
		Setshego	AGR	wear(s)	too much	blanket

In example (10) above the adverb *thata* creates a visibility problem i.e. in terms of visibility conditions. The distance between the verb *apara* and the NP *kobo* is not suitable for Case assignment hence the ungrammaticality of the sentence. Theoretically speaking, the verb cannot see the NP *kobo*. This means that the NP *kobo* has to immediately follow the verb *apara* in order to get Case. Example (10) above is therefore a violation of subjacency conditions as well as the Case-filter. Example (11) below proves this point:

11.	Setshego	o	apara	kobo	thata
	N	AGR	V	N	ADV
	Setshego	AGR	wear(s)	blanket	too much

### 2.3.1.2 THETA ROLE ASSIGNMENT

Now we will focus on the assignment of  $\Theta$ -roles. As we stated earlier transitive verbs are  $\Theta$ -role assigners. According to the theta-criterion they can only assign the internal  $\Theta$ -role to the object NP and the external  $\Theta$ -role to the subject NP. Let us consider example (12) below.

12.	Pule	o	rata	dijo
	N	AGR	V	N
	Pule	AGR	like(s)	food

In example (12) above the object NP *dijo* is assigned an internal  $\Theta$ -role. The subject NP *Pule* is assigned the external  $\Theta$ -role (agent) by the same verb.

To this point, we have been citing examples of sentences which do not have object-clitics (or object concords: both terms being traditional terms<sup>1</sup>). Object clitics are words which bring agreement (of person, number, etc.) between the verb and the object NP. They are called clitics because their occurrence in a syntactic string depends on the presence of a verb. Example (13) below and its tree-diagram in (14) illustrate this:

13.	Shoadi	oa	mo	rata	Setshego
	N	AGR	(oc)	V	N
	Shoadi	AGR		love(s)	Setshego

14.

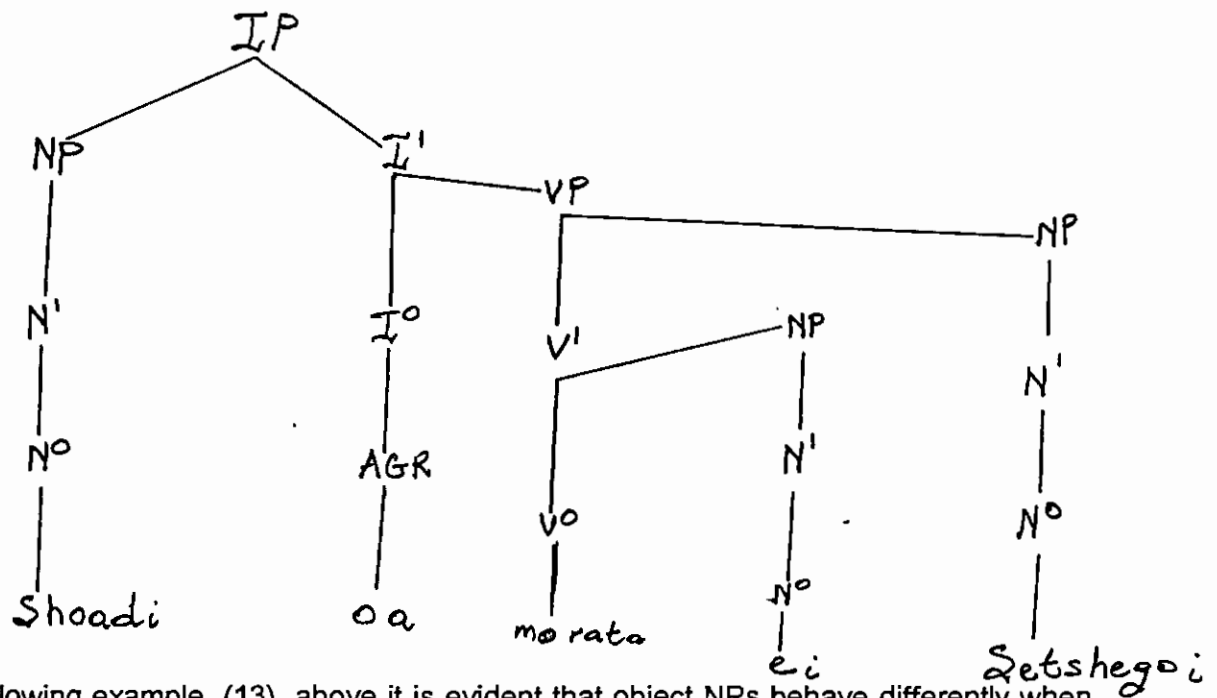

Following example (13) above it is evident that object NPs behave differently when object-clitics are added to a syntactic string. Note that the inclusion of an object-clitic *mo* brings with it the inclusion of the *a*-element in the present indicative (I do not intend to make sequence of inclusion a big issue in this case<sup>2</sup>). Khoali (1992) argues that the *a*-element is an absorber of Case hence the movement of the object NP.

The presence of an *a*-element therefore creates an empty category. An empty category is a trace left by an item (in this case an NP) after it has moved via the mechanism called move-alpha. This is so because items are allowed to move in G.B. i.e. items are nomadic. This movement is however, guided by principles.

The addition of the *a*-element in example (13) above forces the NP *Setshego* to move to an adjoined position - see example (7) in this case a VP adjoined position. This is called Chomsky adjunction. According to the Projection principle, subcategorization properties should be retained at all levels of representation, i.e. D-structure, S-structure and L.F. The empty category we referred to earlier is therefore there to denote the fact that there was an item on that position before movement took place.

The next question is about whether or not Case assignment and  $\Theta$ -role assignment are in any way 'affected' by the addition of the *a*-element. The answer to this question is simply negative. It is worth noting that both the *a*-element and the object-clitic are grammatical features and not lexical features. Consider example (15) below:

15.	Pule	oa	e	rata	thuto
	N	AGR	(oc)	V	N
	Pule	AGR		love(s)	education

In example (15) above the NP thuto which is an object NP is assigned accusative Case by the verb in its first position. Theta-role assignment is also not affected in that the internal  $\Theta$ -role is assigned to the object NP in its first position and so these assigned features are retained by the chain which links the adjoined object NP to the trace. Thus both the Case-filter and the  $\Theta$ -criterion are satisfied. Movement is from an A position (i.e. argument position) to an adjoined position.

### 2.3.2 DITRANSITIVE VERBS

Some verbs take two object NPs and therefore would not qualify in examples (14) and (15) above. Such verbs are called ditransitive verbs. Example (16) and (17) below illustrate this:

16.	Tladi	o	fa	motho	dijo
	N	AGR	V	N	N
	Tladi	AGR	gives	person	food

17.	Modise	o	kwalela	mosetsana	lekwalo
	N	AGR	V	N	N
	Modise	AGR	write(s)	girl	(a) letter

A tree diagram for ditransitives must have the following structure as in example (18) below:

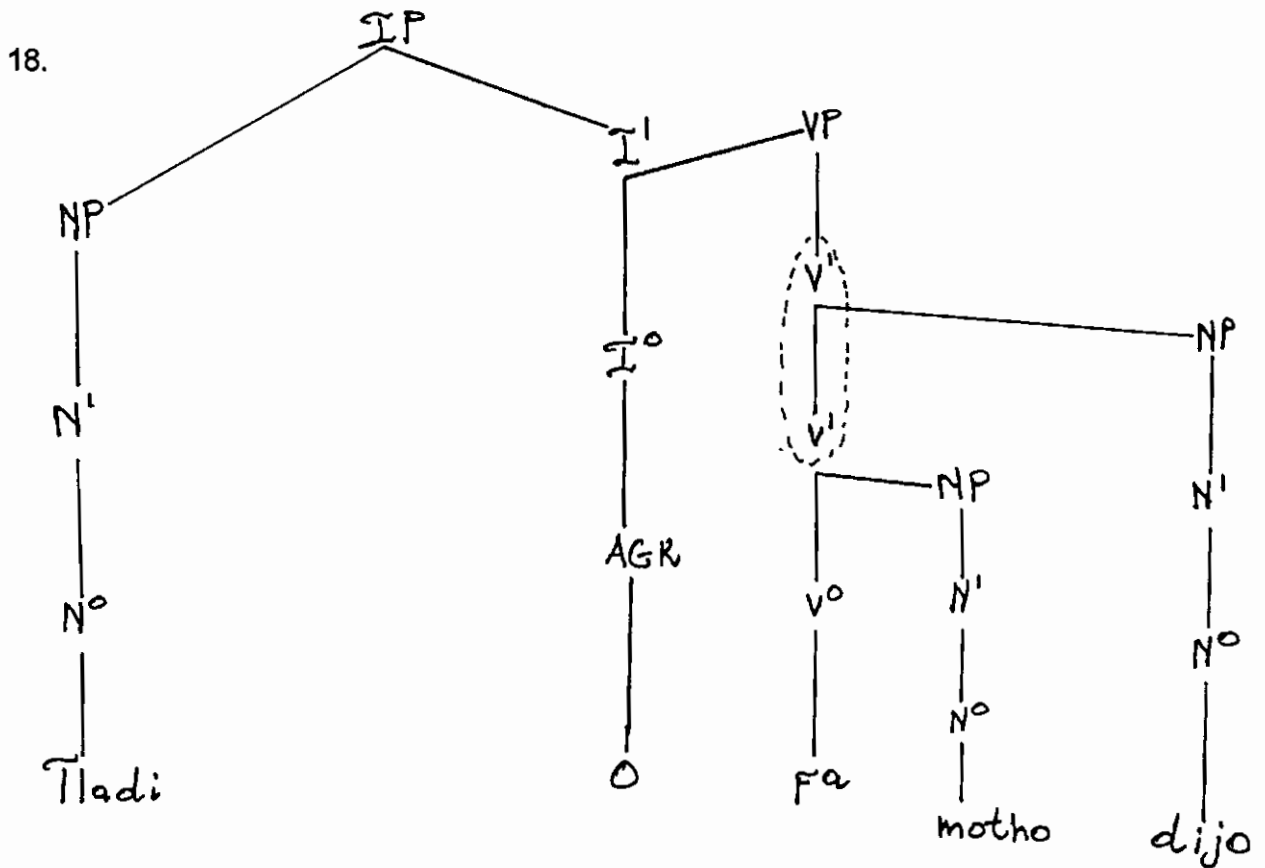

Furthermore, ditransitives can be formalized in the grammar as shown in example (19) below:

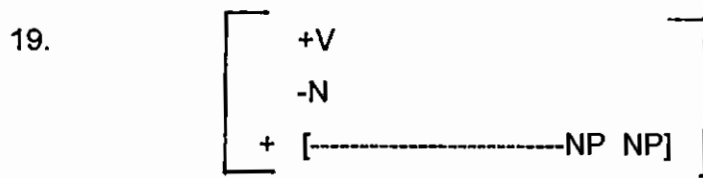

The latest generative formalization is : fa, < NP NP > (Ag, Ben, Pat). In this way, the ditransitive verbs can only occur in sentences which have two object NPs. The first NP is regarded as an indirect object; whereas the second object NP is regarded as a direct object, 'traditionally speaking'.

When discussing transitive verbs we mentioned visibility conditions which are important to the assignment of both Case and  $\Theta$ -roles. The problem with ditransitives is that unlike transitives we have two NPs instead of one on the object position. This means that we have to question the assignment of Case and  $\Theta$ -role vis-a-vis the second NP, by this we mean that the second NP is not immediately subjacent to the VP and therefore Case cannot be assigned (to the second NP) simply because Case assignment takes place under subadjacency. Thus visibility conditions have to apply in this case.

Haegeman (1992) suggests that in instances where the second NP does not get structural Case such an NP obtains abstract Case or inherent Case. In this way, she delineates a second kind of Case. If it were not so, the Case filter would be violated.

Now we will ponder over the assignment of  $\Theta$ -role in terms of the second NP because there seems to be a problem even in this regard. The  $\Theta$ -criterion states that one  $\Theta$ -role should be assigned to one argument and that one argument must be assigned one and only one  $\Theta$ -role. For a moment it looks like the ditransitive verb is assigning two internal theta-roles and one external  $\Theta$ -role which makes it a total of three  $\Theta$ -roles all in all, thus violating the  $\Theta$ -criterion. This however, should not be a problem in that ditransitives are lexically determined i.e. in terms of their distribution and subcategorization features. This predicts that it is within their nature to assign two internal theta-roles and therefore this makes them an exception to the rule. Thus the  $\Theta$ -criterion is also satisfied.

The other thing is that ditransitives seem to be sensitive to the addition of the a- element and object clitics on the other hand. Let us consider examples (20) - (24) below:

20.	Modise	o	ba	fa	dijo	bana
	N	AGR	(oc)	V	N	N
	Modise	AGR		give(s)	food	children
21.	Setshego	o	ba	kwalela	makwalo	bana
	N	AGR	(oc)	V	N	N
	Setshego	AGR	(oc)	write(s)	letters	children
22.	Modimo	o	ba	utlwela	botlhoko	batho
	N	AGR	(oc)	V	N	N
	God	AGR	(oc)	feel(s)	sorry	people
23.	* Modise	oa	ba	fa	dijo	bana
	N	AGR	(oc)	V	N	N
	Modise	AGR	(oc)	give(s)	food	children

24.	*	Dillo	oa	ba	fepa	borotho	batho
		N	AGR	(oc)	N	N	N
		Dillo	AGR	(oc)	feed(s)	people	food

Examples (20), (21) and (22) are all grammatical but notice examples (23) and (24). The reason for the ungrammaticality of examples (23) and (24) can be traced to the fact that firstly, the a-element has been included in the sentence and so it absorbs Case. Secondly, because the first NP in the configuration < NP NP > bear the thematic role of patient and then followed by those that bear the thematic-role of benefactive. However, due to the lack of the a-element in examples (20), (21) and (22) the sentences remain grammatical even after the addition of the object-clitic. Notice that even in this instance movement still takes place. Take note of trees in examples (25), (26) and (27) below which illustrate examples (20), (21) and (22) above respectively.

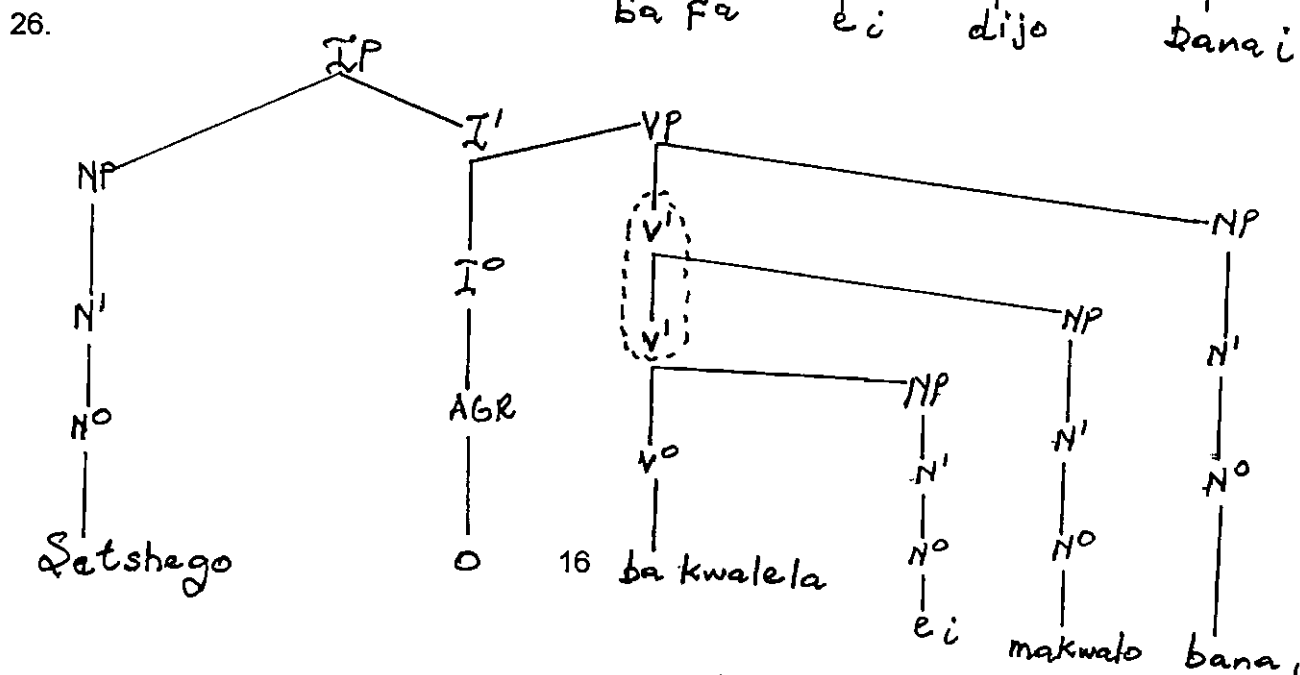
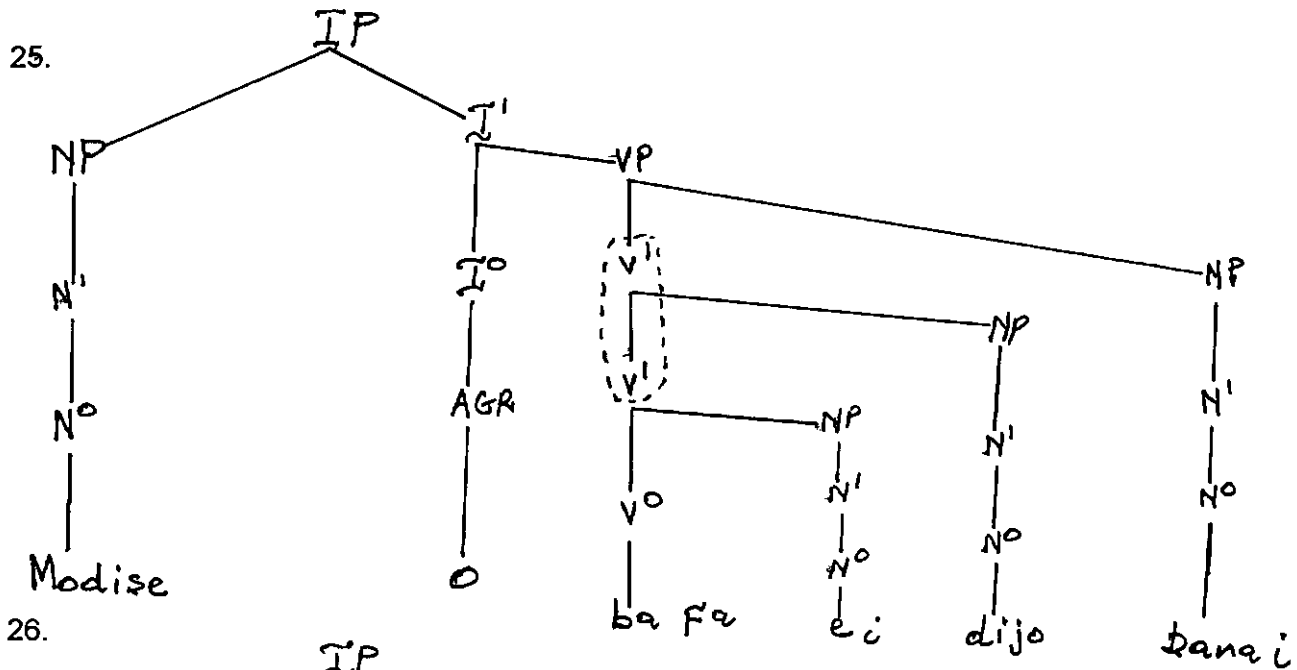

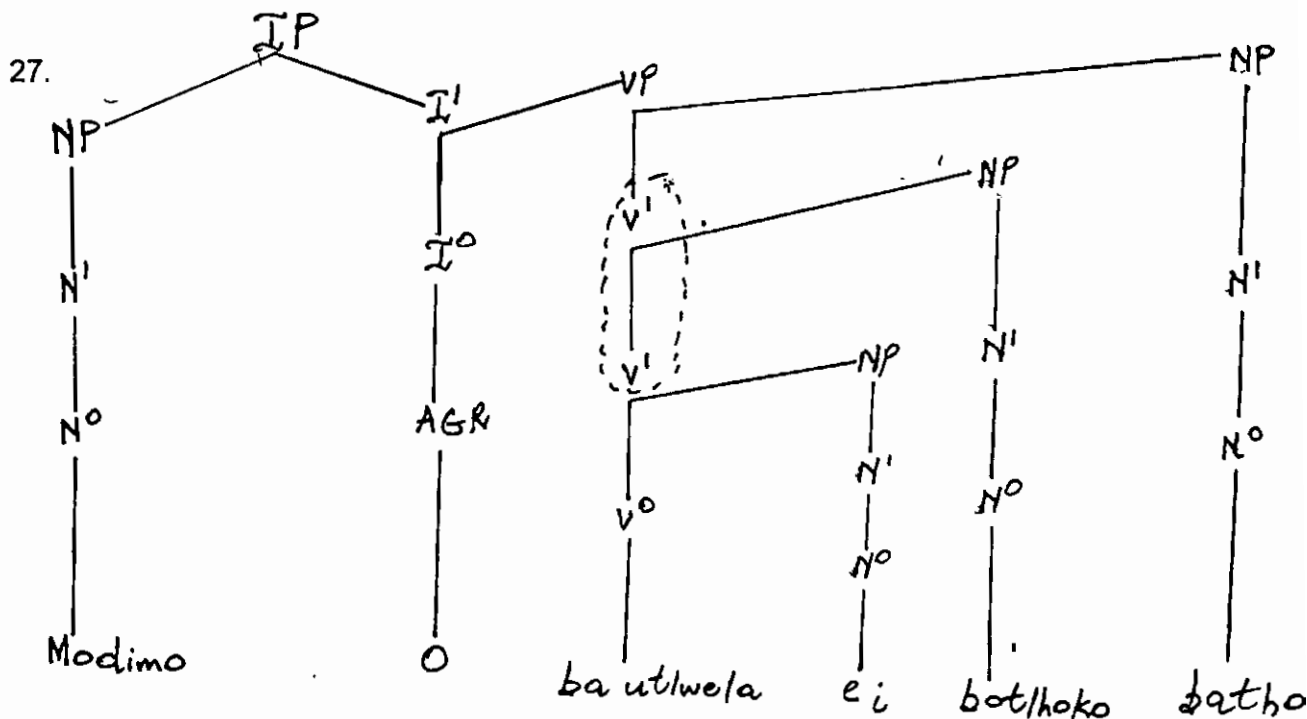

In examples (25), (26) and (27) above it is evident that the nomadic NP between the two object NPs is the one which bears the thematic-role of benefactive i.e. it is the one which moves to the position of adjunction (chomsky adjunction) in this case VP adjunction. This is clearly another movement enforced by the addition of the object-clitic. The vacating NP will then obtain its accusative Case and internal  $\Theta$ -role from its first position via a chain. The following example proves that ditransitives can and do accommodate modifiers in their configuration. For example, adverbs. Consider example (28) below:

28.	Modimo	o	utlwela	batho	bothoko	thata
	N	AGR	V	N	N	ADV
	God	AGR	feel(s)	for people		too much

We will now focus our attention on the Intransitive verbs in the section that follows.

### 2.3.3 INTRANSITIVE VERBS

Intransitive verbs are those verbs which do not take an object NP. This means that they co-occur with constituents in a sentence other than an object NP e.g. a subject NP. Thus the only crucial participant (Lexical item) in their context is the subject of the sentence. In this case an example such as (29) below together with its tree-diagram in (30) will serve the purpose of illustrating our point.

29.	Pule	o	sule
	N	AGR	V
	Pule	is	dead

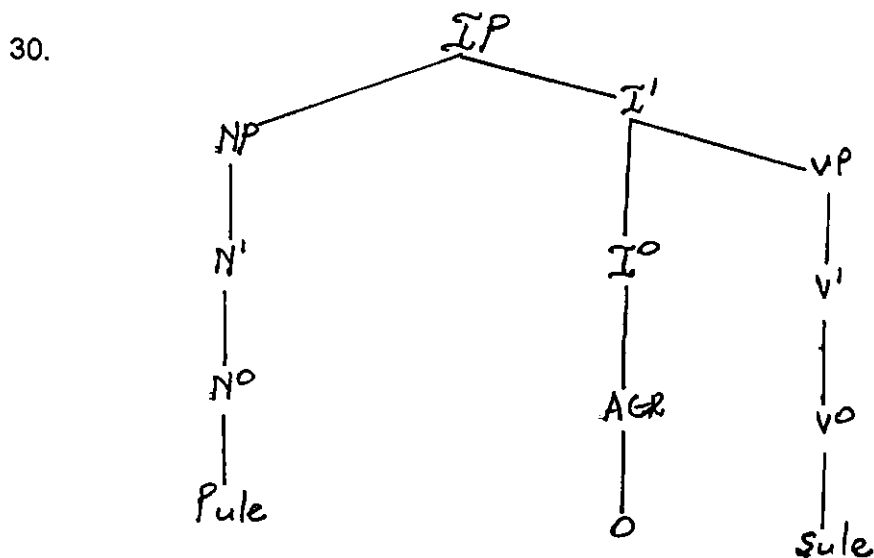

Example (29) above is a typical example of an SV sentence. Heageman (1992) calls intransitive verbs non-accusatives simply because they do not assign accusative Case to the object NP due to the fact that they do not subcategorize for object NPs. This predicts that intransitive verbs can only occur in sentences where the assignment of the accusative Case by the verb is not required. It is therefore self-evident that the only Case assignment that occurs in sentences where the intransitive verbs are used is the nominative Case. Consider examples (31), (32) and (33) that follows below:

31.	Motlalepula	oa	tsamaya
	N	AGR	V
	Motlalepula	is	going/walking

32.	Keboneilwe	o	robetse
	N	AGR	V
	Keboneilwe	is	asleep

33.	Bana	ba	ja
	N	AGR	V
	Children	are	eating

In examples (31), (32) and (33) above the subject NPs obtain their nominative Case from INFL. There are certain intransitives which can at 'will' (or by choice) subcategorize for object NPs. The verb *ja* is one such verb. Consider example (34) that follows below:

34(a)	Bana	ba	ja	borotho
	N	AGR	V	N
	Children	are	eating	bread

Consider the following examples as well:

34(b)	Pule	o a	tshwenya
	N	AGR	V
	Pule	is	troublesome

34(c) NB:	Pule	o	tshwenya	batho
	N	AGR	V	N
	Pule	AGR	annoys	people

34(d)	Serame	o	dira	tiro
	N	AGR	V	N
	Serame	is	doing	work
	Serame	is	working	

In a case such as example (34(a) - (d)) above, Hoekstra (1984) postulates a concept called ergativity i.e. those verbs which subcategorize for object NPs by choice are called ergative verbs and therefore they are exceptional.

Intransitive verbs also do not accommodate object-clitics due to the absence of object NPs. Example (35) below illustrates this point:

35.	*	Pule	oa	mo	tsamaya
		N	AGR	(oc)	V
		Pule	AGR	walks	him/her

However, intransitive verbs can accommodate modifiers in post-verbal slots. Notice example (36) that follows below:

36.	Pule	o	tsamaya	thata
	N	AGR	V	ADV
	Pule	AGR	walk(s)	too much

As for  $\Theta$ -roles assignment, the intransitive verbs can only assign external  $\Theta$ -roles to object NP. This point also boils down to the absence of the object NP. On the other hand, ergative verbs can only assign both the accusative Case and the internal  $\Theta$ -role in the presence of an object NP. However, if the object NP is by choice left out then they only remain potential Case and internal  $\Theta$ -role assigners.

In this way the intransitive verbs can be formalized in the grammar as shown in example (37) below:

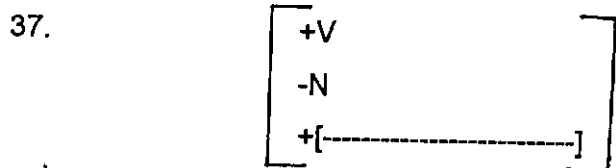

The latest generative formalization is : dutse < - > (Agent)

Chapter 2 has shown us the types of verbs possible in Tswana. We will now attend to Verbal extensions in Chapter 3.

## CHAPTER 3

### 3.1 VERBAL EXTENSIONS

Verbal extensions are grammatical morphemes that can be added between the verb root and the verbal ending. Consider the verbal roots in examples (1) and (2) above and when they are extended in examples (38) and (39) given below:

38.	Motho	o	batlela	bana	dijo
	N	AGR	V	N	N
	Person	AGR	seek(s)	children	food
	Person		seek(s)	food for children	
39.	Mosimane	o	ratisa	mosetsana	mosese
	N	AGR	V	N	N
	Boy	AGR	makes/cause	to love girl	dress
	Boy	causes	the girl to	love a	dress

In examples (38) and (39) above the verbal roots '-batl-' and '-rat-' are extended by the applied and causative morphemes respectively. Note the difference in the argument structure of the extended verbs. Firstly, the verb *batla* in example (1) above is followed by one object NP. However, in example (38) when *batla* is extended, it is followed by two object NPs. The same applies to the verb *rata* in example (2). The verb *rata* is followed by only one object NP namely *mosetsana* in example (2), but in example (39) when *batla* is extended by means of an affix it is followed by two object NPs in a syntactic string. This is so because some extensions add or delete theta-roles to the verb. Looking at examples (38) and (39) above one is obliged to conclude that the addition of some extensions to the verbal root carries with it some syntactic implications. Thus verbal extensions affect the distribution of verbs in a sentence.

The scope of verbal extensions covers the following types of affixes: Passive, Reciprocal, Causative, Applied, Intensive, Extensive, Neuter-passive or Quasi-Passive, Reversive and Reflexive. (Guma 1971).

It is worth noting that only one underlying extension has to be established and a variation thereof is referred to as an allomorph which is a result of phonological rules. However, it is not the aim of this dissertation to discuss such phonological processes.

We shall now discuss the various argument structures (thematic roles) brought by the addition of various extensions to the verbal roots. Firstly, we shall illustrate the argument structure of the Causative morpheme in examples (40) and (41) below:

CAUSATIVE

40.	Motho	o	batlisa	ngwana	dijo
	N	AGR	V	N	N
	Person	AGR	cause to seek/want children	food	
	Person		causes children to want	food	

41.	Mosimane	o	ratisa	mosetsana	batho
	N	AGR	V	N	N
	Boy	AGR	cause to love girl	people	
	Boy	AGR	makes the girl to love	people	

In examples (40) and (41) above the causative morpheme -is- has been added to the verb roots '-batl-' and '-rat-' respectively. In their unextended form the two verbs take only one object NP (refer to examples (1) and (2) above). However, when they are extended by the causative morpheme they take two object NPs as in examples (40) and (41) above. This means that they are immediately followed by two object NPs in a sentence. This for a moment predicts that a causative morpheme is followed by two object NPs. Consider examples (42) and (43) below:

42.	*	Motho	o	batlisa	ngwana
		N	AGR	V	N
		Person	AGR	cause to want child	

43.	*	Mosimane	o	ratisa	mosetsana
		N	AGR	V	N
		Boy	AGR	cause to love girl	

Examples (42) and (43) above are unacceptable (i.e., ungrammatical) because the causative morpheme is followed by one object NP. Nevertheless, let us consider the following examples.

44.	Morutabana	o	badisa	bana
	N	AGR	V	N
	Teacher	AGR	makes/cause to read	children
	Teacher	is	teaching the	children

45.	Seleke	o	tshegisa	batho
	N	AGR	V	N
	Seleke	AGR	makes/cause to laugh	people
	Seleke	AGR	amuses the	people

In examples (44) and (45) above the causative morpheme is followed by one object NP and yet the sentences remain grammatical. This derives from the fact that the verbs bala and tshega do not take an object NP in their unextended form. Notice examples (46) and (47) below:

46.	Bana	ba	bala
	N	AGR	V
	Children	are	studying

47.	Seleke	oa	tshega
	N	AGR	V
	Seleke	is	laughing

Thus the Causative morpheme takes two object NPs when it is attached to a verb which takes one object NP. On the other hand, the causative morpheme takes one object NP when it is added to a verb which does not take an object NP. Verbs that take one object NP are traditionally called transitive verbs, those which take two object NPs are called ditransitive verbs and those that do not take an object NP are called intransitive verbs. Henceforth we shall use these terms.

We have seen how the Causative morpheme can be added to both the intransitive verbs and transitive verbs. Now we shall test the behaviour of ditransitive verbs vis-a-vis the Causative morpheme. Take note of examples (48) and (49) given below:

48. \* Modise o fisa bana dijo  
 N AGR V N N  
 Modise AGR cause to give children food

49. \* Dillo o fepisa batho borotho  
 N AGR V N N  
 Dillo AGR cause to feed people bread

In examples (48) and (49) above the addition of the Causative morpheme is repulsive thus yielding ungrammatical sentences. This predicts that the Causative morpheme cannot be added to ditransitive verbs. We will now look at the other possible contexts for the occurrence of the Causative morpheme. Note examples (50) - (53) below:

50. Morutabana o ratisa bana go bala  
 N AGR V N S [infinitive]  
 Teacher AGR cause to love children to read  
 Teacher causes children to love reading

51. Moruti o ba batlisa nnete gore ba atlege  
 N AGR (oc) V N S [finite]  
 Pastor AGR cause them to want truth for them to succeed  
 Pastor causes them to want the truth for them to succeed

52. Setshego oa ba tlisa batho  
 N AGR (oc) V N  
 Setshego AGR cause people to come

53. Setshego o ratisa batho kereke thata  
 N AGR V N N ADV  
 Setshego AGR cause people to love church too much

In examples (50) above the extended verb *ratisa* is followed by an object NP plus an infinitival clause. In example (51) above the extended verb *batlisa* is followed by an object NP plus a finite clause. In example (52) above the extended verb *tlisa* is used in context with the *a*-element. In example (53) the extended verb *ratisa* is followed by two object NPs plus an optional Adverb. The next consideration is whether or not a causative morpheme can be used with other verbal extensions within a single verbal structure. Consider examples (54) - (61) given below:

54. Pule o batlisiwa dijo  
 N AGR V N  
 Pule is caused to want food  
 (Causative -is- + Passive -(i)w-)
55. Pule o batlisana dijo le Mpho  
 N AGR N N P N  
 Pule is caused to want food with Mpho  
 (Causative -is- + Reciprocal -an-)
56. \* Pule o batlisela Mpho dijo  
 N AGR V N N  
 Pule AGR cause to want (applied) food for Mpho  
 (Causative -is- + Applied -el-)
57. Moruti o ba batlisisa nnete  
 N AGR (oc) V N  
 Pastor AGR cause them to want truth (intensively)  
 (Causative -is- + Intensive -isis-)
58. Batho ba batlakisa ngwana dijo  
 N AGR V N N  
 People AGR cause to want (extensively) child food  
 People cause child to want food extensively  
 (Causative -is- + Extensive -ak-)

59. \* Pule oa batlisega  
 N AGR V  
 Pule is caused to want (Quasi-Passive)  
 (Causative -is- + Q. Passive -eg-)

60. \* Pule o batlisolola dijo  
 N AGR V N  
 Pule AGR cause to unwanted food  
 (Causative -is- + Reversive -lol-)

61. Pule o ipatlisa dijo  
 N AGR V N  
 Pule AGR cause (himself) to want food  
 (Causative -is- + Reflexive -i-)

In examples (54) - (61) above the asterisk shows the ungrammatical sentences i.e. ungrammatical sentences in this case are examples of verbal extensions which cannot be used together with the Causative morpheme in a single verbal structure. Those sentences without the asterisk are examples of verbal extensions which can be used in the same context with the causative morpheme.

There are also rare cases where three affixes can be used within the same verbal structure. Consider example (62) below:

62. Pule o batlakisiwa dijo  
 N AGR V N  
 Pule AGR is caused to want food (extensively)  
 (Causative -is- + Extensive -ak- + Passive -iw-)

Having established the possible contexts in which the Causative morpheme occurs we will now focus on the potential of the Causative morpheme as both a theta-role assigner and Case assigner.

In cases where the Causative morpheme takes one object NP (e.g. (44) and (45) above) then we say it presupposes the need for two arguments namely one argument

internally and another argument externally. In this way, the Causative morpheme will assign one thematic-role (most likely that of Patient) to the object position, this is the internal theta-role. The other thematic-role will be assigned externally to the subject position. In this case a thematic-role of Agent.

In cases where the Causative morpheme takes two object NPs (e.g. (40) and (41) above) then we say that one theta-role is assigned externally and two theta-roles are assigned internally. For a moment this may seem like a violation of the theta-criterion which states clearly that the verbal head must assign one theta-role externally and internally. However, when one considers the fact that a verbal extension is a grammatical morpheme and not a lexical morpheme and that its addition to the verbal root (i.e. in this case) is accompanied by the occurrence of another grammatical item namely the second NP, then it will not be a squib to say that the verbal head in this case assigns two internal theta-roles.

Concerning the assignment of Case the verb extended by a Causative morpheme will assign accusative Case if it takes one object NP but in cases where it takes two object NPs, then the first object NP in the configuration <NP NP> will receive accusative Case from the verb and then the second NP will receive abstract Case or inherent Case. In this way, both the theta-criterion and the Case-filter will be satisfied. However, there are instances where Case assignment might be absorbed. Consider example (63) below:

63.	Rre	oa	tshegisa
	N	AGR	V
	Father	is	amusing

In example (63) above the addition of the a-element in the present indicative brings about an absorption of Case, hence the absence of the object NP. (Khoali 1992).

#### APPLIED

Secondly, we shall illustrate the argument structure of the Applied morpheme in examples (64) and (65) given below:

64.	Modise	o	gotsetsa	Modiegi	molelo
	N	AGR	V	N	N
	Modise	AGR	kindles	Modiegi	fire

65.	Motlalepule	o	leretse	Rre	dijo
	N	AGR	V	N	N
	Motlalepule	AGR	bring	Father	food
	Motlalepule	has	brought	Father	food

In example (64) and (65) above the applied morpheme/extension - el- has been added to the verbal roots '-gots-' and '-ler-' respectively. In their unextended form the two verbs take only one object NP. However, when they are extended by the applied morpheme they take two object NPs as in examples (64) and (65) above. Thus transitive verbs are changed to become ditransitive verbs when extended by the Applied morpheme. We will now test the behaviour of intransitive verbs when extended by the Applied morpheme. Let us look at examples (66) - (68) below:

66.	Baruti	ba	robalela	batho
	N	AGR	V	N
	Pastors	AGR	rest in peace when they are dead	

67.	Digalase	di	lelela	boatleng
	N	AGR	V	N (loc)
	Glasses	are	clicking	

68.	Rre	o	tsamaela	nageng
	N	AGR	V	N (loc)
	Father		is walking towards	the veld

In examples (66), (67) and (68) above the verbal roots '-robal-', '-lel-' and '-tsamay-' have been extended by the Applied morpheme respectively. These verbs are all intransitive in their unextended form. In example (66) above, the verb robalela is in fact an idiomatic expression and it takes an object NP at the end of the sentence. In examples (67) and (68) above, the extended verbs take locative NPs at the end of the sentence. Most appropriately they take adverbs of place. We will now try to prove that extended intransitive verbs do not take adverbs of place (i.e. even when they are not used as idiomatic expressions). This point is illustrated by means of examples (69) and (70) below:

69.	Jesu	o	swela	batho
	N	AGR	V	N
	Jesus	AGR	dies for	people

70.	Ngwana	o	lelela	dijo
	N	AGR	V	N
	Child	is	crying for	food

There is yet another squibb though concerning the extension of intransitives by the Applied morpheme. Note example (71) given below:

71.	*	Rre	o	tshegela	bana
		N	AGR	V	N
		Father		laughs for	children

Example (71) above is something of a peculiar case in that the extended verb *tshegela* does not take an object NP. Thus not all intransitives extended by the Applied morpheme take an object NP. We will now test the behaviour of ditransitive verbs vis-a-vis the Applied morpheme. Consider the following examples:

72.	Shoadi	o	fela	bana	dijo	mo	sekotlolong
	N	AGR	V	N	N	ADVP	(loc)
	Shoadi	AGR	give(s)	children	food	in	a dish

73.	Setshego	o	fepela	batho	mo	nageng
	N	AGR	V	N	ADVP	(loc)
	Setshego	AGR	feed(s)	people	in	the veld

In examples (72) and (73) above the ditransitive verbs *fa* and *fepa* have been extended by the applied morpheme respectively. In this instance, the extended verbs presuppose the need for an adverb of place (or locative NP) in a slot immediately after the configuration <NP NP>. Note also that the NP which bears the thematic-role of Patient is optional. Notice example (73) above. Without the adverbial Phrase the examples given below would be ungrammatical. Consider examples (74) and (75) below:

81. \* Batho ba .batlelolola lebaka  
 N AGR V N  
 People AGR want (Reversive) for a reason  
 (Applied -el- + Reversive -lol-)

82. Batho ba ipatlela dilo  
 N AGR V N  
 People AGR want things for themselves  
 (Applied -el- + Reflexive -i-)

See the example of the combination Causative + Applied in example (56) above. In this way, examples (76), (77) and (82) are possible combinations in terms of <AFFIX + AFFIX>. However, examples (78), (79), (80), (81) and (56) are not possible combinations hence the ungrammatical sentences. There are also rear cases of the configuration <AFFIX + AFFIX + AFFIX>. Let us look at example (83) below:

83. Bana ba batlakelwa mabaka  
 N AGR V N  
 Children are wanted (extensive) for reasons  
 (Applied -el- + Extensive -ak- + Passive -(i)w-)

We will now focus on the other contexts in which the applied morpheme occurs. Let us look at the following examples:

84. Bana ba batlelwa mabaka a mantshi thata  
 N AGR V N ADVP  
 Children are wanted for very many reasons

85. Basimane ba batlelwa go tsamaya  
 N AGR V S [infinitive]  
 Boys are wanted to go

86. Basetsana ba batlelwa gore ba ipaakanye  
 N AGR V S [infinitive]  
 Girls are wanted so that they should prepare themselves

87.	Bana	ba	batlelwa	thata	go	intsha	bodutu
	N	AGR	V	ADV	S	[infinitive]	
	Children	are	wanted	very	much	to	kill time

88.	Rre	o	kwalela	bana	gore	ba	itlhaganele
	N	AGR	V	N	S	[finite]	
	Father	AGR	write(s)	children	that	they	should hurry

Note that in example (84) above the extended verb is used in context with an adverbial Phrase. In example (85) above the extended verb is used contextually with an infinitival sentence, i.e. it takes a sentence. In example (86) it takes a finite sentence. In example (87) it is used in context with an adverb plus an infinitival clause. In example (88) the extended verb takes both an object NP plus a finite clause.

The argument structure of the Applied morpheme is essentially -el- AFFIX <NP NP> (Agent, Benefactive, Patient). Furthermore, clauses are also feasible in post verbal slots. Thus one thematic-role is assigned externally and the other two thematic-roles are assigned internally.

The verb extended with an Applied morpheme will also assign accusative Case to the first NP in the configuration <NP NP> and the second NP will obtain abstract Case. Note that unlike the Causative morpheme the Applied morpheme cannot be used in the same syntactic string with the a-element. See example (89) below:

89.	*	Rre	oa	batlela
		N	AGR	V
		Father	is	wanted (Applied)

Having established the morphology and the syntax of the Applied extension we will now focus on the argument structure of the Reciprocal morpheme. Let us consider examples (90) and (91) given below:

90.	Tladi	o	thulana	le	Pule
	N	AGR	V	P	N
	Tladi	AGR	collides	with	Pule

91.	Segole	se	betsana	le	sefofu
	N	AGR	V	P	N
	Cripple	AGR	fight(s)	with a	blind person

In examples (90) and (91) above the reciprocal morpheme *-an-* is added to the verbal roots *'-thul-'* and *'-bets-'* respectively. In their unextended form these verbs take one object NP. Consider examples (92) and (93) below:

RECIPROCAL

92.	Tladi	o	thula	lebota
	N	AGR	V	N
	Tladi	AGR	collides with	a wall

93.	Segole	se	betsa	sefofu
	N	AGR	V	N
	Cripple	AGR	beats a	blind person

Note the difference. When extended by a reciprocal morpheme the verbs in (92) and (93) above presuppose the need for a Prepositional Phrase in (90) and (91) above. In fact, they take a Prepositional Phrase at the end of a syntactic string. We have seen how transitives behave when extended by a reciprocal. We will now analyze the intransitives vis-a-vis the reciprocal morpheme. Note examples (94) and (95) below:

94.	*	Pule	o	swelana
		N	AGR	V
		Pule	AGR	dies (for each other)

95.	*	Rre	o	tsamayana
		N	AGR	V
		Father	AGR	dies (for each other)

Apparently, intransitive verbs do not accommodate the Reciprocal morpheme within their structure. This derives from the fact that Reciprocal morphemes demand two thematic-roles in their context namely that of Agent and Patient. It should be noted that one NP in a sentence can function as either an Agent or Patient and another one

just like that. In this way, it should not be assumed that the subject NP bears the thematic-role of Agent (as it is usually the case) or that the object NP bears the thematic-role of Patient. We will now analyze ditransitive verbs in relation to the reciprocal morpheme. Let us look at the following examples:

96.           Rre           o       fepana       dijo       le       ngwana  
               N           AGR       V           N       P           N  
               Father                    shares       food   with       child

97.           Setshego       o       fana       dimpho   le       Shoadi  
               N           AGR       V           N       P           N  
               Setshego       AGR       shares       gifts   with   Shoadi

In examples (96) and (97) above the Prepositional Phrase recurs. This predicts that the addition of the Reciprocal morpheme to ditransitive verbal roots fosters the occurrence of a Prepositional Phrase.

We will now use this moment to analyze the argument structure of the Reciprocal morpheme in terms of other possible contexts. Firstly, we will test the likelihood of having combinations between the Reciprocal morpheme and other verbal extensions within a single verbal structure. Note examples (98) - (104) below:

98.           Go       batlanwa       le       ena  
               Inf.       V           P           N  
               She/He is searched for  
               (Reciprocal -an- + Passive -(i)w-)

99.           Bana           ba       batlisana       dijo  
               N           AGR       V           N  
               Children       AGR       cause each other to search for food  
               (Reciprocal -an- + Causative -is-)

100.          Borre           ba       batlisana       mabaka  
               N           AGR       V           N  
               Fathers       AGR       search (intensive) for reasons  
               (Reciprocal -an- + Intensive -isis-)

101.           Batho        ba        batlakana    mabaka  
                   N            AGR        V            N  
                   People     AGR        want reasons from each other (extensive)  
                   (Reciprocal -an- + Extensive -ak-)

102. \*         Batho        ba        batlanega    mabaka  
                   N            AGR        V            N  
                   People     AGR        search (Q. Passive) for reasons  
                   (Reciprocal -an- + Q. Passive -eg-)

103. \*         Batho        ba        batlololana   mabaka  
                   N            AGR        V            N  
                   People     AGR        search (Reversive) for reasons  
                   (Reciprocal -an- + Reversive -lol-)

104. \*         Batho        ba        ipatlana     mabaka  
                   N            AGR        V            N  
                   People     AGR        (Reflexive) want reasons  
                   (Reciprocal -an- + Reflexive -i-)

The combination for Reciprocal and Applied is in example (77) above. In this way examples (98), (99), (100), (101) and (77) are possible combinations, however, examples (102), (103) and (104) are not possible matches. There are also rear cases of the configuration <AFFIX + AFFIX + AFFIX> within the same verbal structure. Note example (105) given below:

105.           Bana        ba        batlakisana   dikotlolo  
                   N            AGR        V            N  
                   Children    AGR        cause each other to search for dishes  
                   (Reciprocal -an- + Extensive -ak- + Causative -is-)

The following are the possible other contexts for the occurrence of the Reciprocal morpheme:

106.           Bana           ba     batlana     mme   ga   ba   bonane  
               N           AGR       V           Con. S [finite]  
               Children are looking for each other but they can't find each other
107.           Batho           ba     jarisana     morwalo   gore   ba   thusege  
               N           AGR       V           N       S [finite]  
               People           are sharing the burden to relieve each other
108.           Bakapelo       ba     ratana       go   isa   lesong  
               N           AGR       V           S [infinitive]  
               Lovers           AGR love each other to death
109.           Basweu         ba     ratana  
               N           AGR       V  
               Whites           AGR love one another
110.           Olebogeng     oa     ratana  
               N           AGR       V  
               Olebogeng     is     in love
111.           Bantsho        ba     ratana       thata  
               N           AGR       V           ADV  
               Blacks           AGR love one another very much

In examples (106) and (107) above the Reciprocal morpheme takes a finite clause. In example (108) an infinitival clause; in example (109) the object NP is absent; in example (110) the Reciprocal is used in conjunction with the a-element in the present indicative and in example (111) above the Reciprocal is used in context with an adverb.

The Reciprocal morpheme does not assign accusative Case instead the preposition is the one which assigns accusative Case (because prepositions are also Case assigners) to the NP which falls within its governing category. Concerning the assignment of theta-roles the Reciprocal morpheme assigns both the internal theta-role and the external theta-role. Note that this morpheme also brings a change to the

argument structure in that it is accompanied by a Prepositional Phrase. Thus -an-AFFIX <PP> (Agent, Patient). Let us illustrate the argument structure of the Intensive morpheme. Consider the following examples:

#### INTENSIVE

112.            Basetsana    ba        batlisisa    nnete  
                   N            AGR        V            N  
                   Girls            are searching (intensive) for the truth

113.            Ngwana        o        dirisisa     tiro    ya    gagwe  
                   N            AGR        V            N  
                   Child            is        doing (intensive) his/her work

In examples (112) and (113) above the intensive morpheme -isis- has been added to the verbal roots '-batl-' and '-dir-' respectively. In their unextended form these verbs are transitive. This implies that the intensive morpheme can be added to transitive verbs. Following this, we will check the condition of intransitives vis-a-vis the intensive morpheme and mutatis mutandis we will also check the behaviour of ditransitives. Let us look at the following examples:

114. \*        Pule            oa        robalisisa  
                   N            AGR        V  
                   Pule            is        sleeping intensively

115. \*        Bana            ba        tsamaisisa  
                   N            AGR        V  
                   Children        are        walking intensively

Note the difference in examples (114) and (115) above. Both examples yield unacceptable sentences when the Intensive morpheme is added to the intransitive verbs. Thus there is a problem with intransitives (unaccusatives). In the same breath, let us look at the following examples:

116. \*        Pule            o        fepisisa    batho    dijo  
                   N            AGR        V            N        N  
                   Pule            is        feeding    people    food    intensively

117. *	Olorato	o	faisisa	bana	borotho
	N	AGR	V	N	N
	Olorato	is	giving	children	bread intensively

Examples (116) and (117) above give an impression that ditransitives do not augur well for the intensive morpheme. Thus ditransitives are also problematic. In the following examples we illustrate the attributes of the Intensive morpheme when used in juxtaposition to other verbal extensions.

118.	Segole	se	batlisisiwa	nnete
	N	AGR	V	N
	Cripple	is	caused to search for truth	intensively
	(Intensive	-isis-	+ Passive	-(i)w-)

119.	Bana	ba	batlisisana	nnete
	N	AGR	V	N
	Children	are	helping each other to search for the truth	
	(Intensive	-isis-	+ Reciprocal	-an-)

120.	Batho	ba	mpatlakisisa	nnete	
	N	AGR	V	N	
	People	are	making me to search for truth	intensively	
	(Intensive	-isis-	+ Reflexive	-i- + Extensive	-ak-)

121. *	Go	batlisisega	nnete	
	Inf.	V	N	
	It is wanted	truth	intensively	
	(Intensive	-isis-	+ Q. Passive	-eg-)

Note well that the combinations -isis- + -is- and -isis- + -el- are in examples (57) and (78) respectively. Note that examples (78) and (121) are not possible combinations for the intensive morpheme. However, examples (57), (118), (119) and (120) are indeed possible combinations. There is yet another kaleidoscope of possible contexts for the distribution of the intensive morpheme. Consider the following examples:

122. Pule o batlisisa bonnete jwa dikgang  
 N AGR V N P N  
 Pule is searching intensively for the truth of news
123. Bana ba batlisisa nnete gore ba ikgotsofatse  
 N AGR V N S [finite]  
 Children are searching for truth so that they should be satisfied
124. Bana ba batlisisa nnete go ikgotsofatsa  
 N AGR V N S (infinitive)  
 Children are searching for truth to satisfy themselves
125. Olorato o batlisisa nnete thata  
 N AGR V N ADV  
 Olorato is seeking (intensively) for truth too much

Following examples (122), (123), (124) and (125) above, it is clear that the Intensive morpheme can be followed by a prepositional Phrase as in example (122); a finite clause as in example (123), and infinitival clause as in example (124) and an adverb as in example (125).

As for the assignment of theta-roles and Case the following points obtain. Firstly, the Intensive morpheme assigns both the internal  $\Theta$ -role and the external  $\Theta$ -role. Accusative Case is also assigned. Nevertheless, Case can be absorbed if an a-element is used. Note example (126) below:

126. Rre oa batlisisa  
 N AGR V  
 Father is investigating

In example (126) above the a-element is used in the present indicative, hence the absence of the object NP. In this way, -isis- AFFIX <NP> (Agent, Patient). We will now discuss the argument structure of the Passive morpheme. Consider the following examples:

PASSIVE

127.           Dikgomo     di     a     bonwa  
                   N           AGR           V  
                   Cows           are           seen

128.           Bana           ba           ratwa  
                   N           AGR           V  
                   Children       are           loved

In examples (127) and (128) above the Passive morpheme/extension *-(i)w-* has been added to the verb roots *'-bon-'* and *'-rat-'* respectively. In their unextended form, these verbs take an object NP. See examples (129) and (130) below:

129.           Bana           ba     bona     sepoko  
                   N           AGR     V           N  
                   Children       are     seeing    a ghost

130.           Setshego     o     rata     Olebogeng  
                   N           AGR     V           N  
                   Setshego     AGR     love(s)   Olebogeng

Having established the affinity between the transitive verbs and the Passive morpheme, we will now move on to the intransitives and then ditransitives. Take note of the following examples:

131.           Motlalepule   o   a     robalwa  
                   N           AGR           V  
                   Motlalepule   is being slept upon

132.   \*       Motlalepule   o   a     tsamaiwa  
                   N           AGR           V  
                   Motlalepule   is being walked upon

133.           Go           a     tsamaiwa  
                   Inf.        AGR     V  
                   It's        being     walked

Examples (131) and (133) above are acceptable but note example (132). What makes example (132) unacceptable is the fact that it simply does not make sense i.e. semantically speaking. Thus not all intransitives are problematic in this case. We will now check the behaviour of the Passive morpheme in relation to ditransitive verbs. Consider the following examples:

134.	Batho	ba	fiwa
	N	AGR	V
	People	are	given

135.	Bana	ba	fepiwa
	N	AGR	V
	Children	are	fed

Note that in examples (134) and (135) above the ditransitive verbs do not cause a stir when the Passive morpheme is added to thematic-role. There is a wide range of possible contexts for the distribution of the Passive morpheme. Check the following examples:

136.	Bana	ba	ratwa	thata
	N	AGR	V	ADV
	Children	are	loved	too much

137.	Batho	ba	fepiwa	go	fitlha	ba	kgotsofala
	N	AGR	V	S	[infinitive]		
	People	are	fed	until	they	are	satisfied

138.	Bana	ba	jesiwa	dijo	gore	ba	seke	ba	lapa		
	N	AGR	V	N	S	[finite]					
	Children	are	fed	food	so	that	they	should	not	get	hungry

Note the difference between examples (136), (137) and (138) above. The Passive morpheme can be used in configuration with the Adverb (136), infinitival clause (137) and a finite clause (138). The Passive morpheme can also be used within the same verbal structure together with other verbal extensions. See the following examples:

139. Pule o batlakiwa dijo  
 N AGR V N  
 Pule AGR 'wanted' food  
 (Passive -(i)w- + Extensive -ak-)
140. \* Pule o batlegiwa dijo  
 N AGR V N  
 Pule is 'wanted' food  
 (Passive -(i)w- + Q. Passive -eg-)
141. \* Pule o batlololwa dijo  
 N AGR V N  
 Pule is 'unwanted' food  
 (Passive -(i)w- + Reversive -lol-)
142. \* Pule o ipatliwa dijo  
 N AGR V N  
 Pule is 'wanted' food

Note that combinations for Passive + Reciprocal, Passive + Causative, Passive + Applied and Passive + Intensive are found in examples (98), (54), (76) and (117) respectively. Apparently all other combinations are possible apart from examples (140), (141) and (142).

Concerning the assignment of  $\Theta$ -roles the Passive morpheme necessitates the presence of only one argument namely that of Patient on the subject position. This is so because of a number of reasons. The first reason is that the subject position of the Passive verb is assumed to be empty in the d-structure. In this way, the NP on the object position in the d-structure has moved to the subject position in the S-structure via move Alpha ( $\alpha$ ). This means that the NP dikgomo (in example (127) above) leaves a trace behind to mark the fact that the object position was occupied in the d-structure. This movement of NP is forced in honour of the extended projection principle which states that all sentences must have subjects which are phonetically realized.

The second reason is that the Passive morpheme has a tendency of suppressing the assignment of  $\Theta$ -roles on the object position (i.e. internally) and it also has a tendency of absorbing assignment of Case (specifically accusative Case) and as a result of this, the object position on S-structure is left unoccupied and one can only conclude that the argument of Agent is only implied in this case and that it is not phonetically realized. Thus  $-(i)w-$  AFFIX <NP> (Patient).

In the following paragraphs we discuss the argument structure of the extensive morpheme/extension. Let us take a close look at examples (143) and (144) given below:

#### EXTENSIVE

143.	Pule	o	remaka	dikgong
	N	AGR	V	N
	Pule	AGR	chop(s)	wood (extensively)

144.	Modise	o	segaka	nama
	N	AGR	V	N
	Modise	AGR	slice(s)	meat (extensively)

In examples (143) and (144) above the extensive morpheme  $-ak-$  has been added to the verb roots  $'-rem-'$  and  $'-seg-'$  respectively. These are transitive in their unextended form. We will now check the condition of intransitives and then ditransitives vis-a-vis the extensive morpheme. Consider examples (145) and (146) given below:

145. *	Pule	o a	robalaka
	N	AGR	V
	Pule	AGR	sleep(s) (extensively)

146. *	Motshidisi	o a	tsamaaka
	N	AGR	V
	Motshidisi	AGR	walk(s) (extensively)

Examples (145) and (146) above are unacceptable. However, note the difference in examples (147) and (148) below:

147.	Pule	o	robalaka	gotlhe
	N	AGR	V	ADV
	Pule	AGR	sleep(s)	everywhere (extensively)

148.	Motshidisi	o	tsamaaka	masigo
	N	AGR	V	ADV
	Motshidisi	AGR	walk(s)	at night (extensively)

In this way, transitives only remain problematic if they are not accompanied by adverbs. Apparently, transitives take adverbs at the end of a syntactic string when they are extended by means of the extensive morpheme. It is also worth noting that examples (145) and (146) above could be acceptable in pragmatic discourse. We will now move on to the status of ditransitives in the following examples i.e. in terms of the extensive morpheme:

149. *	Pule	o	faaka	bana	dijo
	N	AGR	V	N	N
	Pule	AGR	give(s)	children	food (extensively)

150. *	Aobakwe	o	fepaka	batho	dijo
	N	AGR	V	N	N
	Aobakwe	AGR	feed(s)	people	food (extensively)

Note the problem with ditransitives. When they are extended by an extensive morpheme they become ungrammatical. Thus there is a problem with ditransitives in as far as the extensive morpheme is concerned. We will now check the behaviour of the extensive morpheme when used contextually with other verbal extensions. Consider the following examples:

151. *	Bana	ba	batlakega	thata
	N	AGR	V	ADV
	Children	are	'needed'	very much
	(Extensive	-ak-	+ Q. Passive	-eg-)

152. \* Batho ba dirakolola tiro  
 N AGR V N  
 People are 'undoing' work  
 (Extensive -ak- + Reversive -olol-)

153. \* Batho ba ipatlaka  
 N AGR V  
 People AGR want themselves (extensively)  
 (Extensive -ak- + Reflexive -i-)

154. Batho ba mpatlakaka dijo  
 N AGR V N  
 People AGR want food (extensively)  
 (Extensive -akak- + Reflexive -m-)

Note that combinations for Extensive + Passive; Extensive + Reciprocal; Extensive + Causative; Extensive + Applied and Extensive + Intensive are found in examples (139), (101), (58), (79) and (120) respectively. We will now search for other possible contexts for the distribution of the Extensive morpheme in a sentence. Note the following examples:

155. Pule o remaka dikgong ka selepe  
 N AGR V N ADV  
 Pule AGR hacks wood with an axe

156. Pule o remaka dikgong gore a itse go gotsa molelo  
 N AGR V N S [finite]  
 Pule AGR hacks wood so as to make fire

157. Pule o remaka dikgong thata  
 N AGR V N ADV  
 Pule AGR hacks wood too much

158. \* Pule o remaka dikgong go gotsa molelo  
 N AGR V N S [infinitive]  
 Pule AGR hacks wood to make fire

In example (155) above the Extensive morpheme is used in context with an adverbial Phrase; in example (156) it is used in context with a finite clause; in example (157) it is used in context with an adverb and lastly in example (158) the extensive morpheme does not seem to augur well for the infinitival clause.

Concerning the assignment of  $\ominus$ -roles the following can be said about the Extensive morpheme. This morpheme necessitates the presence of two arguments namely that of Agent on the subject position and that of Patient on the object position. Thus it assigns both the external  $\ominus$ -role and the internal  $\ominus$ -role. The accusative Case is also assigned to the object NP. Thus -ak- AFFIX <NP> (Agent, Patient).

Next on the line is the argument structure of the Neuter Passive/Quasi Passive morpheme. Consider examples (159) and (160) that follows below:

#### QUASI-PASSIVE

159.	Moruti	o a	latlhega
	N	AGR	V
	Pastor	is	getting lost

160.	Ngwana	o a	ratega
	N	AGR	V
	Child	is	lovable

In examples (159) and (160) above the Neuter-Passive morpheme -eg- has been added to the verb roots '-latlh-' and '-rat-' respectively. It should be noted that the Quasi-Passive morpheme shares most sub-distribution features with the Passive morpheme. In their unextended form the verbs in examples (159) and (160) above are transitive. Note examples (161) and (162) below:

161.	Pule	o	latlha	dijo
	N	AGR	V	N
	Pule	AGR	throws away	food

162.	Pule	o	rata	batho
	N	AGR	V	N
	Pule	AGR	loves	people

In the following paragraphs we discuss the status of intransitive and ditransitives in relation to the Quasi-Passive morpheme. Consider the following examples:

163.	Tsela	e a	tsamaega	
	N	AGR	V	
	Road	is	walkable	
164.	Katlele	e a	robalega	
	N	AGR	V	
	Bed	is	sleepable	
165.	Batho	ba	fepega	
	N	AGR	V	
	People	are	feedable	
166. *	Bana	ba	fega	dimpho
	N	AGR	V	N
	Children	AGR	'givable'	gifts

Following example (163) and (164) it looks as though the unaccusatives i.e. intransitives augur well for the Quasi-Passive morpheme. Ditransitives also fit in with the Quasi-Passive morpheme apart from exceptional cases like example (166) above. Furthermore, we will analyze the condition of the Quasi-Passive morpheme when used within the same verbal structure together with other verbal extensions. See the following examples:

167. *	Batho	ba	batlegolola	dijo
	N	AGR	V	N
	People	AGR	'unwant'	food
	(Q. Passive	-eg-	+ Reversible	-olol-)
168 *	Bana	ba	ipatlega	
	N	AGR	V	
	Children	AGR	want themselves	
	(Q. Passive	-eg-	+ Reflexive	-i-)

Combinations for Quasi-Passive + Passive; Quasi-Passive + Reciprocal; Quasi-Passive + Causative; Quasi-Passive + Applied; Quasi-Passive + Intensive and Quasi-Passive + Extensive are found in examples (140), (102), (59), (80), (121) and (151) respectively. We will now check possible other contexts for the distribution of a Quasi-Passive morpheme in a sentence. Consider the following examples:

169.           Go    batlega    thuto    gore    batho    ba    tshele    botoka  
 Inf.        V           N        S [finite]  
 Education is needed for the prosperity of the people

170.           Go    batlega    barutegi    mo    lefatsheng    la    rona  
 Inf.        V           N        ADV  
 Inf.    Wanted    educated    people    in    our    land  
 Educated people are needed in our land

171.   \*       Pula       e       batlega    go    fedisa    komello  
           N        AGR       V        S [infinitive]  
 Rain     is       needed    to       eradicate    drought

In example (169) above the Quasi-Passive morpheme is used contextually with the finite clause; in example (170) it is used with an adverbial Phrase and in example (171) it does not seem to augur well for the infinitival clause.

Concerning the assignment of  $\Theta$ -roles the Quasi-Passive morpheme suppresses the internal  $\Theta$ -roles and assigns the external  $\Theta$ -role and it also absorbs the assignment of the accusative Case. Thus -eg- AFFIX  $\leftrightarrow$  (Patient)

Following the Quasi-Passive morpheme is a discussion about the argument structure of the Reversive morpheme. Note that semantic overtures are embedded within the Reversive morpheme. Consider the following examples:

#### REVERSIVE

172.           Modise           o       sokolola    batho  
           N            AGR        V           N  
 Modise        AGR        convert(s)    people

173.	Mosimane	o	dirolola	tiro
	N	AGR	V	N
	Boy	AGR	undo(es)	work

In examples (172) and (173) above the Reversive morpheme '-lol-' has been added to the verb roots '-sokeg-' and '-dir-' respectively. In their unextended form these verbs are transitive. See examples (174) and (175) below:

174.	Pule	o	sokegile	mekgwa
	N	AGR	V-PAST	N
	Pule	is	corrupt	

175.	Pule	o	dira	tiro
	N	AGR	V	N
	Pule	is	doing	work

Having established the status of transitives vis-a-vis the Reversive morpheme we will now move on to the status of intransitives and ditransitives. Consider the following examples:

176.	*	Pule	o	robolola	boroko
		N	AGR	V	N
		Pule	is	reversing	his sleep

177.	*	Motlalepule	o	tsamaolola	loeto
		N	AGR	V	N
		Motlalepule	is	reversing	her journey

178.	*	Pule	o	fepolola	batho	dijo
		N	AGR	V	N	N
		Pule	AGR	'unfeeds'	people	food

179.	*	Pule	o	folola	batho	dimpho
		N	AGR	V	N	N
		Pule	AGR	'ungives'	people	gifts

Note that the Reversive morpheme does not augur well for both intransitives and ditransitives. This problem should, however, be traced to the semantic interpretation of the morpheme itself. The problem stems from the fact that not every work can be undone (or reversed) i.e. semantically speaking. It would therefore be inappropriate to assume that all transitive verbs are reversible in their semantic interpretation. Look at examples (180) and (181) below:

180. \*      Setshego      o      ratolola      Shoadi  
                  N      AGR      V      N  
                  Setshego      AGR      'unloves'      Shoadi
181. \*      Sisinyane      o      betsolola      ngwana  
                  N      AGR      V      N  
                  Sisinyane      AGR      'unbeats'      a child

Following the discussion above, we will now analyze the status of the Reversive morpheme when it is used within the same verbal structure together with other verbal extensions. Check the following example:

182.            Pule            o            ithatholola      kgwele      mo      thamong  
                  N            AGR            V            N            ADV  
                  Pule            AGR            unties      a      robe      from      his      neck  
                  (Reversive -olol- + Reflexive -i-)

Note that possible combinations for the following morphemes - Reversive + Passive, Reversive + Reciprocal, Reversive + Causative, Reversive + Applied, Reversive + Extensive, Reversive + Quasi-Passive are found in the following examples (141), (103), (60), (81), (152) and (167) respectively. Check the ungrammatical and the grammatical combinations.

As for other contexts in which the Reversive morpheme can be used we count the following:

183.            Pule            o            epolola      bojang      gore      a      bo      leme      gologongwe  
                  N            AGR            V            N            S      [finite]  
                  Pule            AGR            dig(s)      out      grass      so      as      to      plant      it      somewhere

184.	Pule	o	pagolola	diaparo	ka	bonako
	N	AGR	V	N	ADV	
	Pule	AGR	unhangs	clothes	quickly	

185.	Banna	ba	dirolola	tiro go	ikgotsofatsa
	N	AGR	V	S [infinitive]	
	Men	AGR	undo	work to satisfy themselves	

In example (183) above the Reversive morpheme is used within the same syntactic string together with a finite clause, in example (184) it is used with an adverb and in example (185) it is used with an infinitival clause.

The Reversive morpheme presupposes the need for the presence of more than one argument namely that of Agent on the subject position and that of Patient on the object Position. This means that the Reversive morpheme assigns both the internal  $\Theta$ -role and the external  $\Theta$ -role. The reversive morpheme also assigns accusative Case to the object NP. Thus -olo- AFFIX <NP> (Agent, Patient).

Lastly, we will discuss the morphology and the syntax of the Reflexive morpheme. Consider examples (186), (187), (188) and (189) below:

REFLEXIVE

186.	Setshego	o a	ithata
	N	AGR	V
	Setshego	AGR	love(s) herself

187.	Setshego	ga a	ikitse
	N	AGR	V
	Setshego	doesn't	know herself

188.	Bana	ba	nthata
	N	AGR	V
	Children	AGR	love me

189.	Ngwana	oa	sekolo	o	ipolaile
	N	AGR	V	AGR	V
	A	school	child	has	committed suicide

Haegeman (1992) says 'the reflexive and its antecedent must agree with respect to the nominal features of person, gender and number. Thus lack of agreement leads to ungrammaticality' (p. 192). The reflexive morpheme is therefore dependent on its antecedent for its semantic interpretation. In examples (186) and (187) above the subject NP Setshego and the Reflexive morpheme -i- both share the same referent. In this context the NP Setshego binds the Reflexive morpheme because the reflexive morpheme -i- is within the governing category of its antecedent. ('Binding is a principle which states whether or not expressions in a sentence refer to someone or something outside their clause or sentence or whether they are 'bound' within it. For example, in: Setshego o a ithata. Setshego is a referring expression referring to someone in the real world and the morpheme -i- is an anaphor referring to Setshego. It is said to be bound to Setshego'.) (Richards et al 1992)

(Haegeman (1992) defines the concept governing category as follows: 'A reflexive must be bound in the minimal domain containing it, its governor and an accessible subject/SUBJECT). Thus the distance between the reflexive and the referent should be such that the anaphor will clearly and unambiguously relate to the R-expression it seeks to qualify.

The Reflexive morpheme in Tswana is a clitic because it depends on the presence of the basic verb for it to occur in a sentence. The affixation of the Reflexive morpheme -i- and -n- can sometimes result in a phonological change to the verb root. However, phonological discussions would be outside the framework of our dissertation. The reflexive morpheme -n- is an allomorph of the morpheme -i-. We have reason to believe this because -n- is unique and highly restricted in its sentential distribution. Thus -n- is person-oriented and number-specific and therefore cannot be used anyhow. The -i- on the other hand is neither person-oriented nor number-specific nor gender-sensitive. (NB. This is contrary to Haegemann's description of a reflexive).

In examples (186), (187), (188) and (189) above the reflexive morpheme is used in juxtaposition to transitive verbs. We will now check the behaviour of intransitives and then ditransitives when the reflexive morpheme is added to the verbal root. Take note of the following examples:

190.	*	Pule	o a	ithobala	
		N	AGR	V	
		Pule	AGR	sleeps upon himself	
191.	*	Bana	ba	itsamaya	
		N	AGR	V	
		Children	AGR	walk upon themselves	
192.		Bana	ba	ithoballa	
		N	AGR	V	
		Children	AGR	sleep by themselves	
193.		Monna	o a	itsamaela	
		N	AGR	V	
		Man	AGR	walk(s) by himself	
194.		Tello	o	ipha	dijo
		N	AGR	V	N\
		Tello	AGR	give(s)	himself food
195.		Bana	ba	iphepa	marotho
		N	AGR	V	N
		Children	AGR	feed themselves	bread

Note the difference between examples (190) + (191) and (192) + (193). In examples (190) and (191) the Reflexive morpheme is attached to intransitive verbs. In examples (192) and (193) the Reflexive morpheme -i- is still attached to intransitives, however, this time the morphemes are further extended by other verbal extensions hence the production of grammatical sentences. Furthermore, in examples (194) and (195) above things seem to augur well for ditransitives when used in juxtaposition to the reflexive morpheme.

Combinations showing the Reflexive morpheme used within the same verbal structure together with the other verbal extensions are found in the following examples:

-i- + -(i)w- (142);    -i- + -an- (124);    -i- + -is- (61);    -i- + -el- (82);  
 -i- + -isis- (120);    -i- + -ak- (153);    -i- + -eg- (168);    -i- + -olol- (182).

Check the ungrammatical as well as the grammatical combinations. The following examples are about a wide range of other possible contexts for the distribution of the Reflexive morpheme:

196.            Mpono    o    ipakela    mathata    ka go nwa bojalwa  
                   N        AGR    V            N            ADV  
                   Mphono is causing herself problems by drinking liquor

197.            Batshameki    ba    itshiamiseditse go tlhagella kwa kgotla  
                   N                AGR                V            S [infinitive]  
                   Players            are            prepared    to appear in court

198.            Bana                ba    ipololetse gore ga ba kitta ba falola  
                   N                AGR                V            S [finite]  
                   Children            are    convinced that they won't pass

In example (196) above the reflexive morpheme is used in conjunction with an adverbial Phrase, in example (197) it is used in context with an infinitival clause and in example (198) it occurs with a finite clause.

Concerning the assignment of  $\Theta$ -roles and Case the following can be said about the reflexive morpheme. Firstly, the reflexive morpheme is an assigner of only one  $\Theta$ -role and that is the external  $\Theta$ -role of Agent. Thus the internal  $\Theta$ -role is suppressed. The assignment of the accusative Case is also absorbed. Thus -i- AFFIX  $\leftrightarrow$  (Agent).

In sum, the following conclusions can be made about the addition of extensions to verb roots viz:

- (a) That the extensions theta-mark and Case-mark positions for which they subcategorise.
- (b) That these extensions change the argument structure of verbs in some cases whereas in some cases they do not.
- (c) That extensions also subcategorize for complements when added.

Having discussed the verbal structure and the verbal extensions in this chapter, We will now give specific attention to other types of verbs in Chapter 4. We shall also discuss other types of complements apart from those already mentioned in Chapters 2 and 3.

### 3.2 ADDENDUM: THE USE OF SCHEMATIC REPRESENTATIONS

Radford has the following to say about Phrase-markers:

"Sentences have a categorial constituent structure, which can be represented in terms of a Phrase-marker, a Phrase-marker is a type of graph consisting of a set of points (called nodes), with each such point carrying a label and with each pair of nodes being related either by a precedence or a dominance relation. Nodes related by dominance are connected by solid lines called branches. Each constituent in a sentence carries an appropriate category label. Categories are drawn from a highly restricted finite (and putatively universal) set comprising N - NP, V - VP, P - PP, A - AP, ADV - ADVP, D, M, etc." (p.114).

Following what Radford says about Phrase-markers it becomes clear that they serve an expository purpose. Their use is therefore essential for sentence-analysis and sentence-description in that tree diagrams show the relation between the various constituents of a sentence in a formal, explicit and economic manner. Formal because technical representations are used, explicit because they are easy to understand, i.e. provided one is conversant with the technical jargon involved and finally they are economic because they curtail redundancy in terms of longwinded descriptions hence 'schematic' representations.

In syntax, the best way to describe relations among the constituents of a sentence is to start from left to right on printed paper. Thus recursivity in syntax is from left to right as opposed to morphology where recursivity is from right to left. Let us look at examples (199) and (200) that follows below:

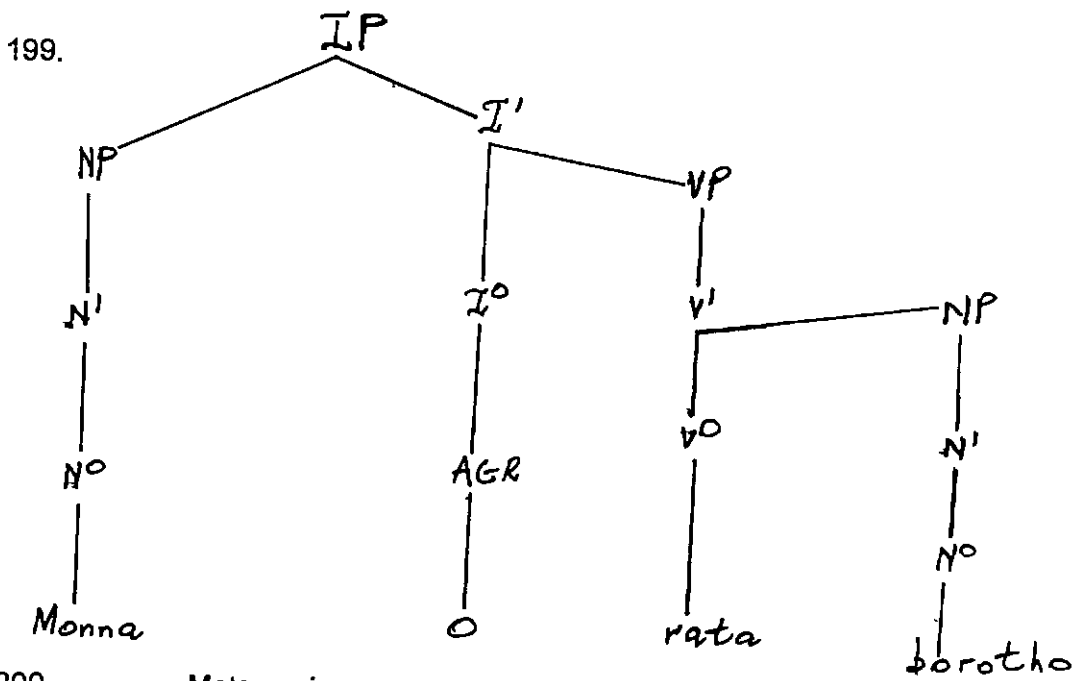

200.                      Motsamai =

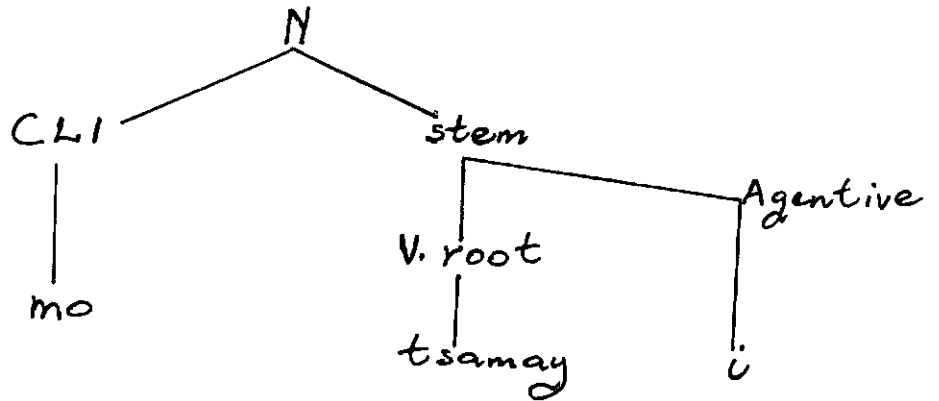

In example (199) above the sentence is analysed from left to right whereas in example (200) the word motsamai is analysed from right to left. In section 3.1 We made reference to the idea that items in a sentence exist in a sisterhood relationship (i.e. if one uses a somewhat non-technical terminology). This stems from the view that items in a syntactic string exist in a hierarchical order, i.e. other items dominate others. Tree diagrams therefore also project the sisterhood relations because of their hierarchical structure. Thus the nodes which appear higher up in a tree dominate those which appear lower. Let us consider example (201) below:

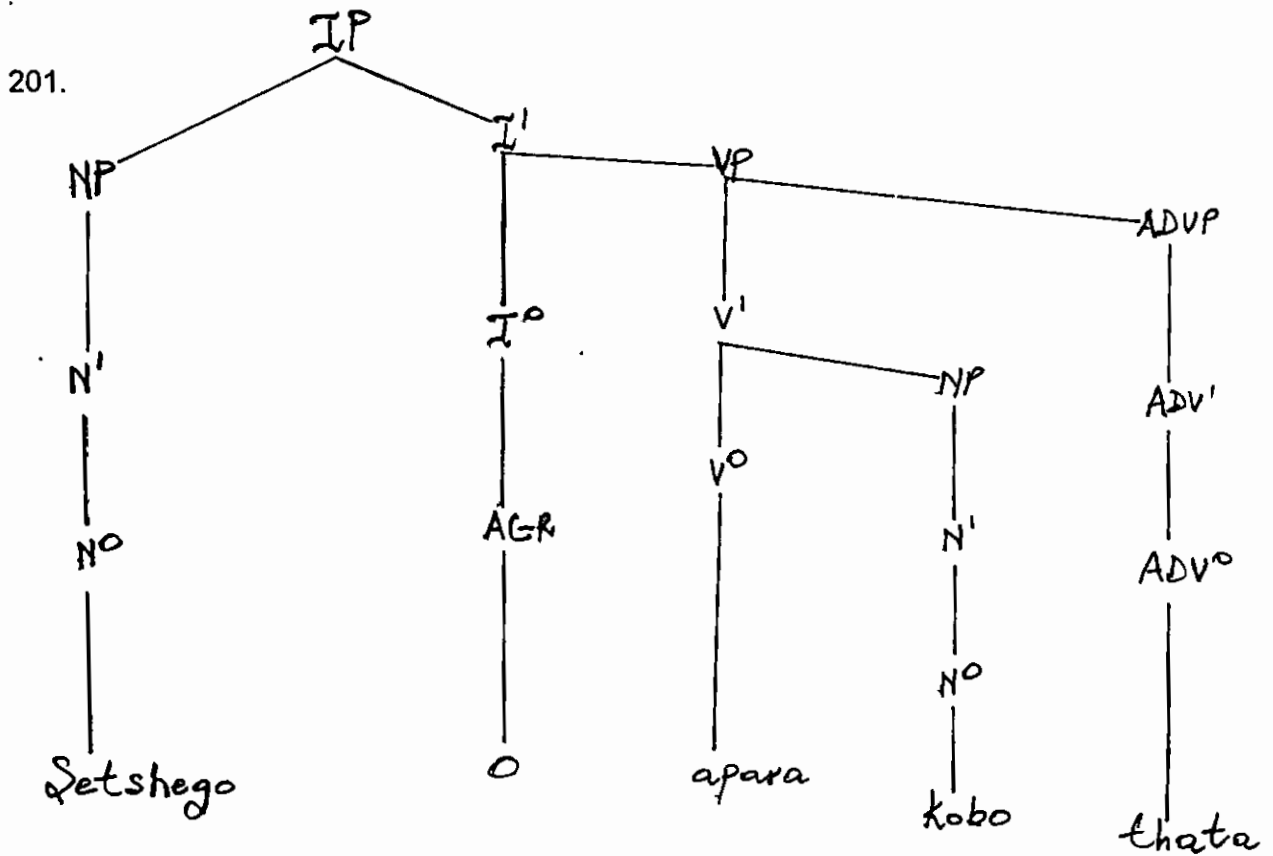

In example (201) above the node IP dominates all nodes because it is the highest node. Thus NP and VP fall under it. Notice VP and the fact that VP immediately dominates V1 and ADVP, but NP (i.e. the NP within VP) is dominated by V1 because it branches from V1. Thus V1 and ADVP are sisters because they share the same mother node, in this case VP. NP is a granddaughter of VP because NP branches from V1 which is the daughter of VP.

Apart from tree diagrams one can also use labelled bracketing to illustrate sentences. These are convenient and sometimes more revealing. They encode the same information as a tree but present it linearly (Sells 1985) consider example (203) that follows below:

203. (a) Shoadi        oa    mo    rata    Setshego  
           N        AGR (oc)    V        N  
           Shoadi        AGR            love(s) Setshego

(b) [IP [NP Setshego] [INFL oa] [VP [V mo rata]  
       [NP [N ej] [NP [N Setshego]]]

We shall therefore use labelled bracketing and tree diagrams in my discussion interchangeably and as I deem fit. The other schematic representation that I want to touch upon is the subcategorization frame. This kind of representation is concerned mainly with categorial features of words in a sentence, i.e. to illustrate lexical categories to which every word belongs, e.g. example (204) below gives categorial features of transitive verbs:

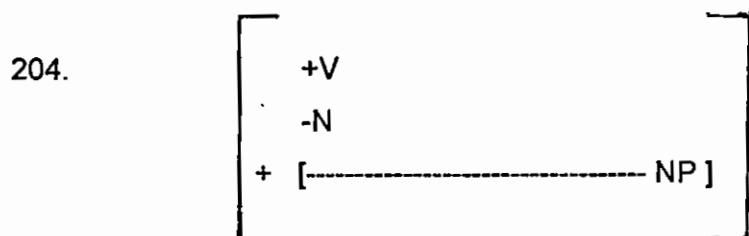

Example (204) above states the category feature of a verb, i.e. the fact that it is a verb and not a noun hence the notation +V to denote the idea that it relates positively with the category verb and negatively with the category noun hence -N. It

also states the subcategory feature of the verb, i.e. the fact that it subcategorizes for an object NP. Another generative formalization is the one that gives a reflection of the theta-role assignment by the verb. Consider example (205) that follows below:

205.           betsa,           < NP >   (Ag, Pat)

A representation in example (204) above is referred to as a theta-grid. Its function is to reflect on thematic roles assigned by the verb. In example (205) above the verb *betsa* subcategorizes for an NP hence the notation < NP > and it assigns an internal theta-role of Patient and an external theta-role of Agent.

## CHAPTER 4

### 4.1 OTHER COMPLEMENTS (SENTENTIAL COMPLEMENTATION)

Certain complements in Tswana are not necessarily NP complements. In fact, they are a wide range of complements which include demonstratives, adjectives and sentential complements. In this section we discuss sentential complementation. Sentential complementation implies that a verb is followed by a sentence instead of an NP complement.

It should however, be noted that this type of complementation is largely determined by the semantic content of the verbs themselves i.e. not all verbs qualify to subcategorize for sentences. Let us look at the following examples:

207.           Ke    batla   Pule   a    dule  
          AGR    V       N    AGR    V  
          I       want   Pule   to     sit

208.           Modise   o    tshotheletsa   batho   go   tsamaya  
                  N    AGR       V            N    Infin    V  
          Modise   AGR   persuade(s)   people   to     leave

209   \*       Modise   o       robala       batho   go   tsamaya  
                  N    AGR       V            N    Infin    V  
          Modise   AGR       sleep(s)   people   to     leave

Note that whereas examples (207) and (208) both augur well for sentential complementation, the latter example i.e. example (209) does not. In the following discussion we therefore investigate cases of sentential complementation with regard to verbs which may or may not subcategorize for sentences. Seeing that two sentences and not one are involved in strings which have sentences as complements, we will explain a few things as regards the linear composition of sentences which typify sentential complementation.

Firstly, the type of sentence formation engaged here is complex and it encompasses

two types of sentences, namely, the main clause (also called the matrix) as well as the subordinate clause (also called the lower clause). Secondly, the matrix contains the verb which subcategorizes for the sentence. In example (207) above the verb *batla* is in the matrix and therefore it is the transitivity verb. The role of the verb in the lower clause is not so important for my discussion.

We will now test the three types of verbs mentioned in Chapter 2 in relation to sentential complementation. We shall start with intransitive verbs in examples (210) - (213) which follow below:

210.	Masole	a	sule	a	lwana
	N	AGR	V	AGR	V
	Soldiers	AGR	died	AGR	fighting

211.	Shoadi	o	robala	gonne	a	tshwerwe	ke	tlala
	N	AGR	V	CP	AGR	V	AGR	V
	Shoadi	AGR	sleeps	because	he	is	hungry	

212.	Pule	o	tsamaya	a	ntse	a	tshega
	N	AGR	V	AGR	Aux.V	AGR	V
	Pule	is	walking	bemused			

213.	Pule	o	dula	a	bala
	N	AGR	V	AGR	V
	Pule	AGR	keeps	on	reading/studying

Note that even though in the examples cited above sentential complementation is used vis-a-vis the intransitive verbs, sentences which follow the matrix can be optionally left out, the same applies to example (209) above. Consider the following examples:

214.	Masole	a	sule
	N	AGR	V
	Soldiers	are	dead

215.           Shoadi       o a           robala  
                   N           AGR           V  
                   Shoadi       is           sleeping
216.           Pule           o a           tsamaya  
                   N           AGR           V  
                   Pule           is           going/walking
217.           Pule           o a           dula  
                   N           AGR           V  
                   Pule           is           sitting

Examples (210) - (213) above should mean that intransitives do accommodate sentential complements. We will now check the status of transitive verbs with regard to sentential complementation. Consider examples (218) - (222) cited below:

218.           Mpho    o   betsa   bana   bao   ba   tlileng   moletlong  
                   N   AGR   V       N       C   AGR   V           N  
                   Mpho   AGR   beats   children   who   have   come   to   the   party
219.           Bana     ba   rata     go   apara   diaparo   tse   dintle  
                   N     AGR   V       Infin.   V           N       ADJ  
                   Children   AGR   like     wearing   beautiful   clothes
220.           Bana     ba   tshwara   ditlhapi   gore   ba   nne   le   dijo  
                   N     AGR   V       N       C   AGR   V       N  
                   Children   are   catching   fish     so   as   to   have   food
221.           Banna    ba     ja     bogobe   gore   ba   tle   ba   kgore  
                   N     AGR   V       N       C   AGR   Aux   AGR   V  
                   Men       are   eating   bread   so   as   to   dispel   hunger
222.           Pule     o     rema   setlhare   gore   a   bone   dikgong  
                   N     AGR   V       N       C   AGR   V       N  
                   Pule     is    chopping   a   tree   so   as   to   get   wood

In the examples given above all transitive verbs register positive for sentential complements. Thus transitives can accommodate sentential complements in their subdistribution. The following discussion is about ditransitive verbs in relation to sentential complements. Consider the following examples:

223.           Tladi       o       fa       motho       dijo       gore       a       je  
                   N       AGR    V       N       N       C       AGR   V  
                   Tladi       AGR   give(s) a person food so that he (person) might eat

224.           Basetsana   ba       fepa       moeng       dijo       gore       a       je  
                   N           AGR    V       N       N       C       AGR   V  
                   Girls           AGR   feed a guest food so that he might eat

Note that even the ditransitives do accommodate sentences as complements in their sentential subdistribution. Thus all types of basic verbs are capable of subcategorizing for sentential complements. (NB. - not all verbs, but all types of basic verbs). It should also be noted that all these types of basic verbs take sentences/clauses optionally. In the following examples we investigate the relationship between the extended verb forms and sentential complementation.

225.           Ngwana       o       bolawa       fa       a       sentse  
                   N           AGR    V       C       AGR    V  
                   A child       is       killed if he has messed up - [Passive]

226.           Bona           ba       ratana       go       isa       losong  
                   N           AGR    V       Infin  
                   They           love    each other to death - [Reciprocal]

227.           Morutabana   o       ratisa       bana       go       bala  
                   N           AGR    V       N       Infin    V  
                   Teacher       AGR   causes children to love reading - [Causative]

228.           Rre           o       kwalela       bana       gore       ba       ithaganele  
                   N           AGR    V       N       C       AGR    V  
                   Father       AGR   write(s) children that they should hurry up - [Applied]



234.           Ke       batla       Mpho     a       je  
 AGR           V           N        AGR     V  
 I             want       Mpho     to       eat

235.           Keboneilwe   o       gapeletsa   batho   go   tsamaya  
               N        AGR           V           N        Infin.   V  
 Keboneilwe   AGR           forces   people   to       leave

Also consider the tree diagrams of the examples cited above as they follow below:

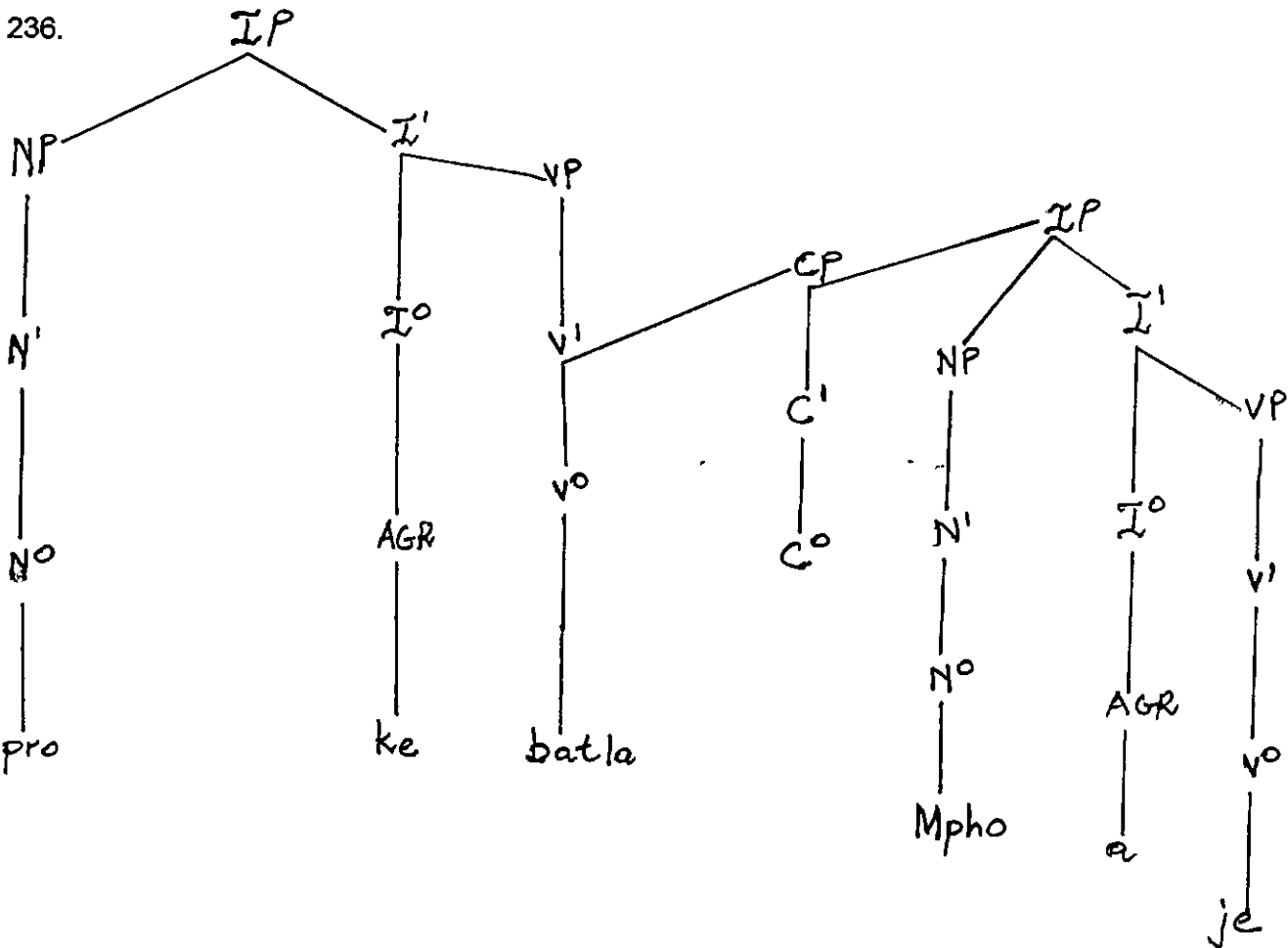

237.

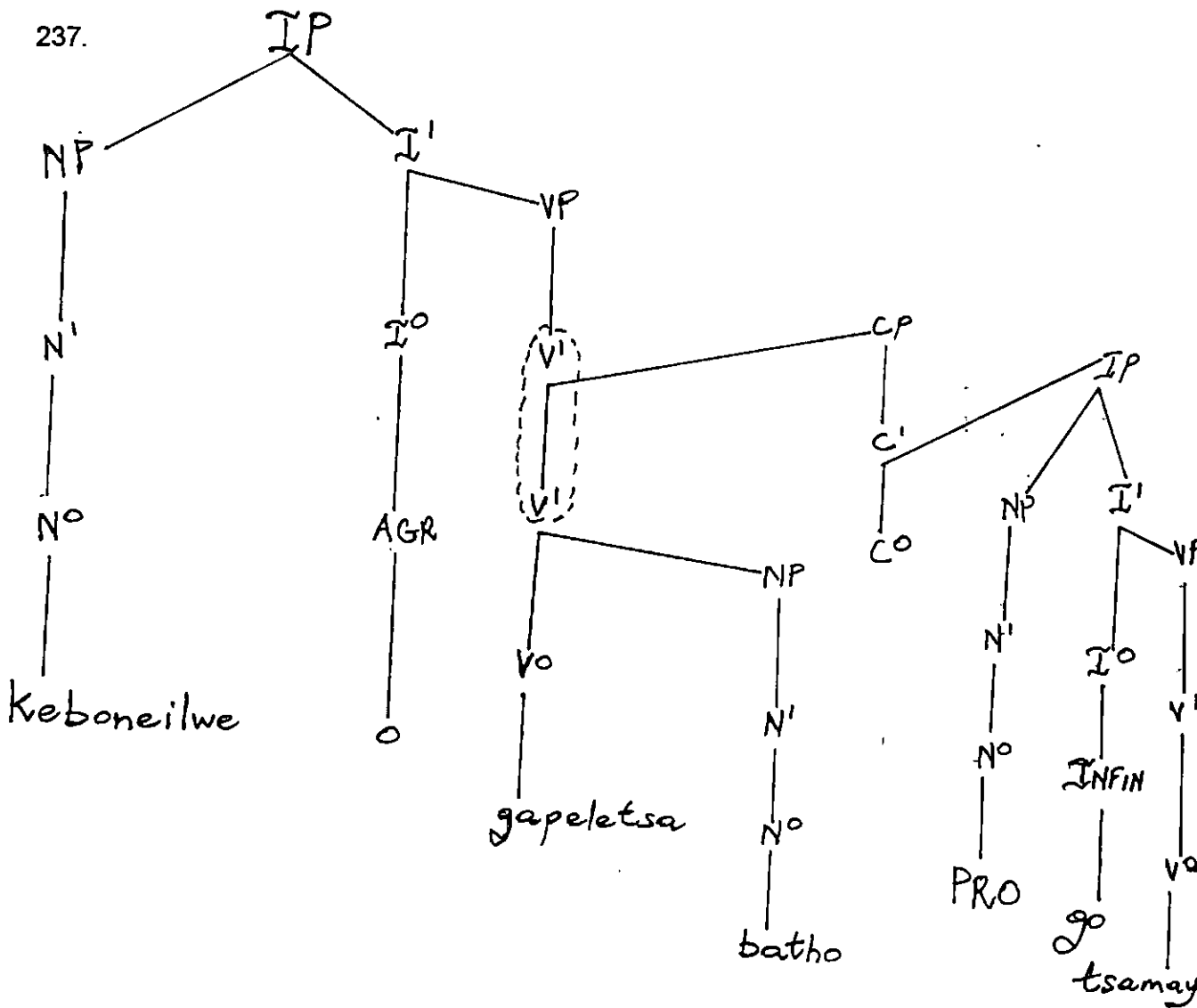

Note that in diagrams (236) and (237) above the verbs *batla* and *gapeletsa* are both shown/illustrated as subcategorizing for a CP complement. In diagram (237) CP serves as barrier to government i.e. it prevents/inhibits the verb *gapeletsa* from governing big PRO in the lower clause. This derives from the fact that big PRO should be left (and necessarily so) as a free agent in its governing category.

Big PRO will therefore neither be governed by the verbal head in the matrix nor get nominative Case from the infinitival 'go' because the infinitive 'go' is not tensed and therefore does not qualify to assign Case (Sells 1985). Thus the subject position of the infinitive clause is not a position to which Case is assigned.

It is worth noting that the CP on the terminal nodes (i.e. lexical items) can be made to optionally occur or not to occur. Consider example (234) above which does not have a phonetically noticeable CP and when it does in example (238) which follows below:

238.           Ke    batla   gore   Mpho   a   je  
 AGR    V    CP    N    AGR   V  
 I       Want   CP   Mpho   to   eat

Example (234) is a paraphrase which roughly represents example (238). The following tree diagram represents example (238) above:

239.

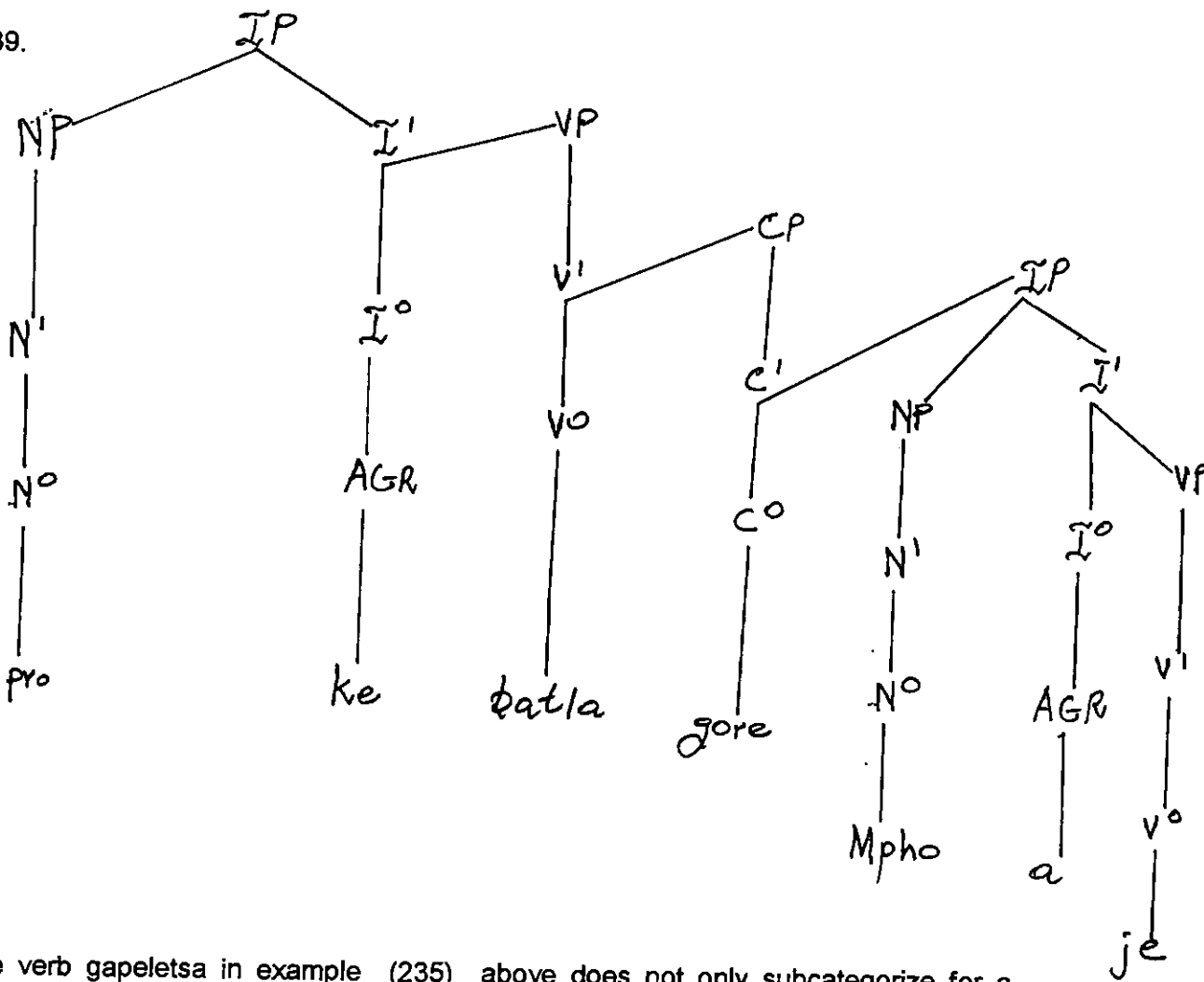

The verb gapeletsa in example (235) above does not only subcategorize for a clause but it also subcategorizes for an NP complement. In this case the NP batho. Thus the configuration for complementation stands as follows: < NP CP>. The verb batla subcategorizes for only a CP complement. Thus the batla type subcategorizes for only a CP and the gapeletsa type for an NP CP. The following examples typify the batla type. Let us look at them:

240.           Go       bonala   bale   mo   leetong  
 Infin.        V        AGR        ADV  
 It            seems   they are on a journey

241.           Go       batlega    re       dire    ka    natla  
 Infin.        V       AGR     V       ADV  
 It is necessary for us to work hard

Examples (242) and (243) are typical of the gapeletsa type/class:

242.           Pule     o     tshotheletsa    bana    go    tsamaya  
           N     AGR       V           N     Infin.    V  
 Pule    AGR    persuades    children   to    go/leave

243.           Modisé   o     itsise     bana    gore    o    falotse  
           N     AGR     V       N       C     AGR    V  
 Modise AGR    informs    children   that he has passed

We have made an observation that the batla type of verbs behave like transitive verbs (hence only CP) and the gapeletsa type on the other hand does behave like a ditransitive (hence NP CP). In the following subsection we discuss sentence embedding.

#### 4.1.2 SENTENCE EMBEDDING

We will now look at the effect (if any) that sentence embedding can have on the subcategorization features of verbs. Sentence embedding is essentially about one sentence tucked-up in another, what is traditionally referred to as complex sentences. Consider the following examples:

244.           Monna   yo    o     tsamayang    o    gobaditswe   maabane  
           N     C    AGR     V       AGR     V           ADV  
 A man who is leaving was hurt yesterday

245.           Mosimane yo   ba    mo    gobaditseng   o    tšile   maabane  
           N     C    AGR   OC       V       AGR   V       ADV  
 The boy whom they hurt has arrived yesterday

Also consider tree diagrams in (246) and 247) below:

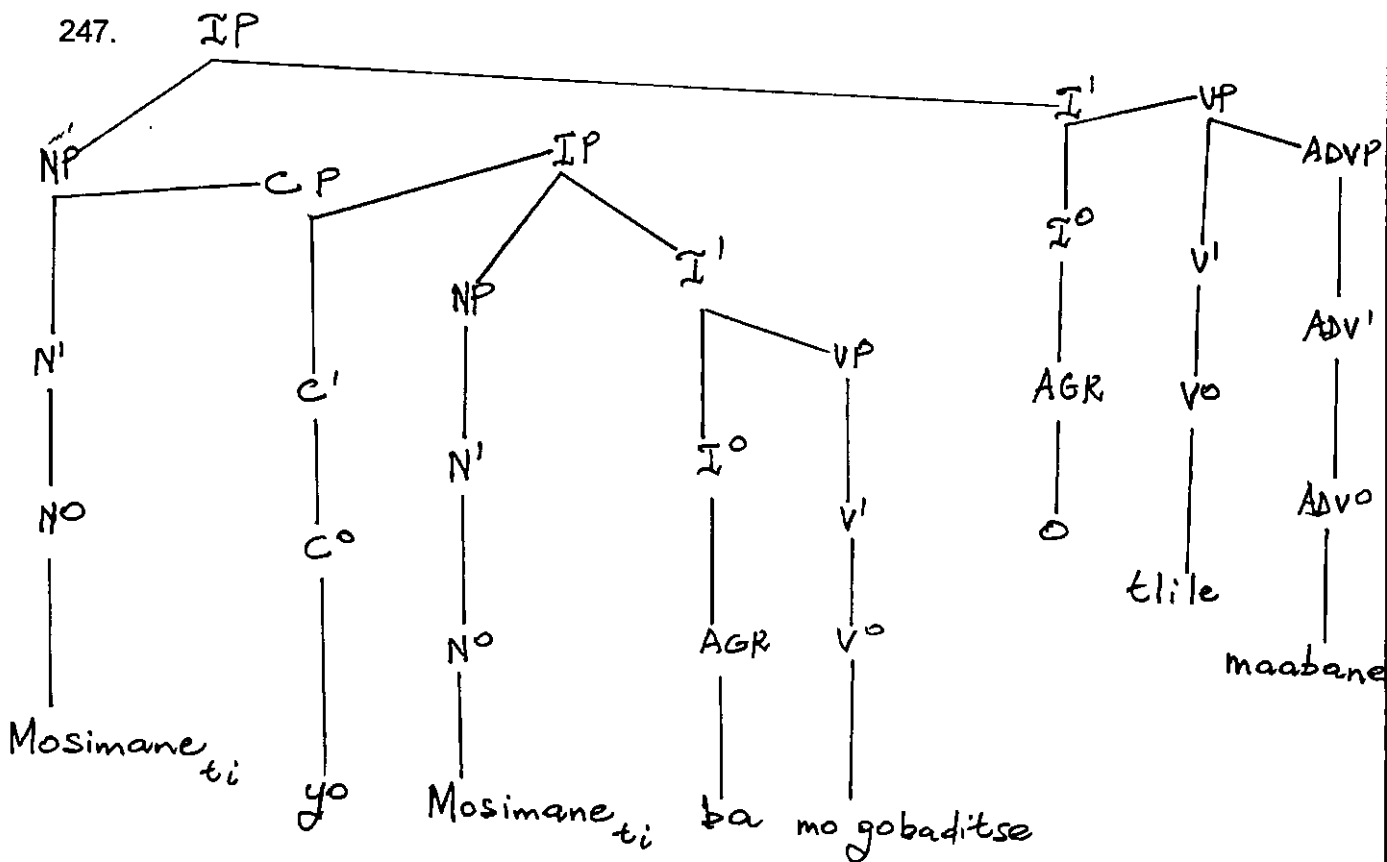
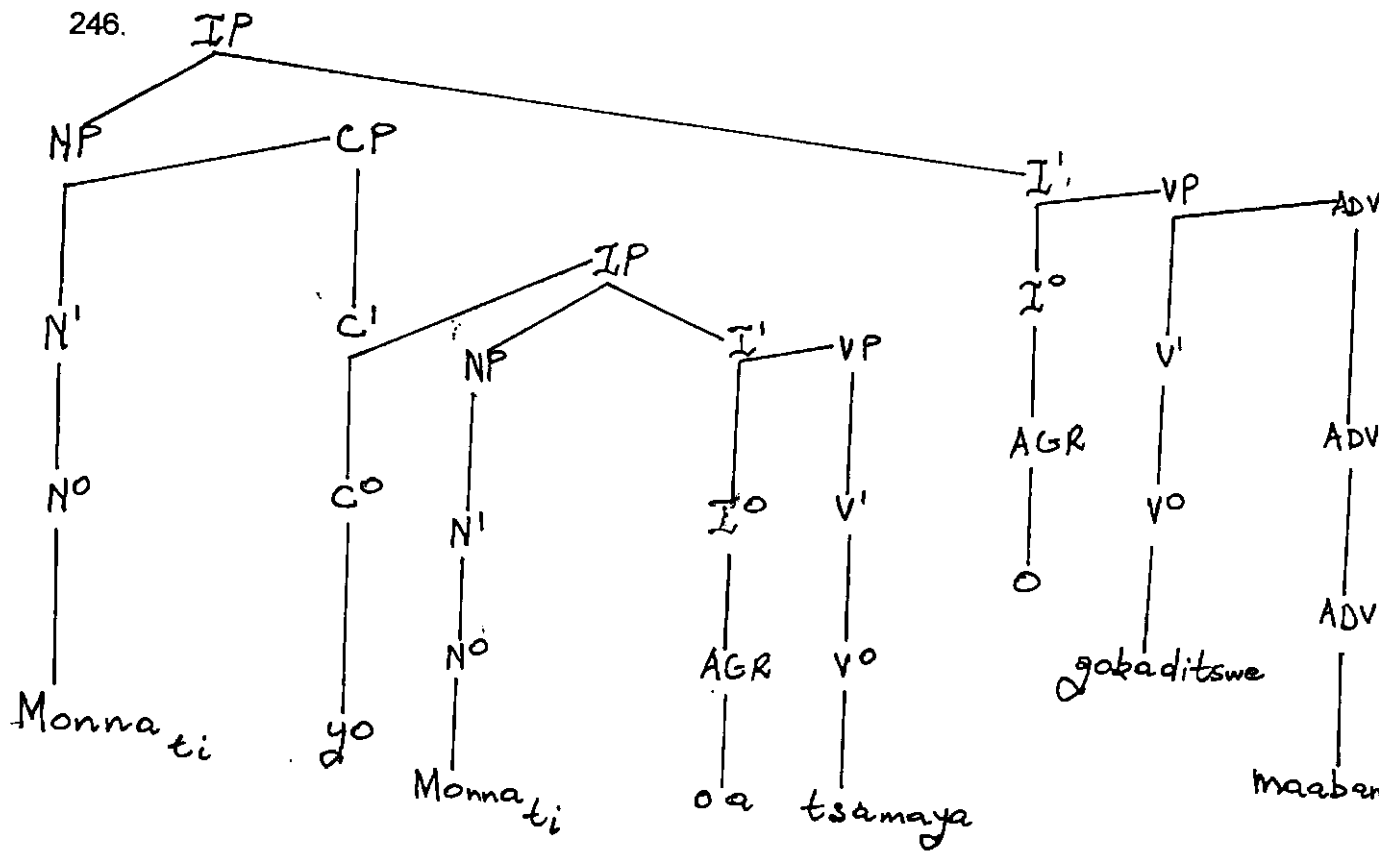

In the given examples above two types of relative clauses are used namely the direct and the indirect relative clauses. These are embedded in the main clause. It is worthwhile to note that the verb in the relative clause (also subordinate clause) will subcategorize for anything that occurs within the framework of the clause itself and nothing outside the clause. Thus the verbs *tsamayang* and *gobaditseng* in examples (244) and (245) respectively are restricted in terms of their subcategorization capacity and so they cannot subcategorize for anything in the matrix. Having discussed the status of the verb in the embedded clauses we will now discuss Auxiliary verbs in the following section.

#### 4.2 AUXILIARY VERBS (STRICT SUBCATEGORIZATION)

In general auxiliary verbs indicate the time when the process takes place, the duration of the process or some nature of the process. Auxiliary verbs are different from basic verbs in terms of the following aspects:

- (a) Auxiliary verbs cannot take object NPs as verbs do. This is illustrated in examples (248) and (249) below:

248.	*	Bana	ba	ntse	nama
		N	AGR	Aux.V	N
		Children	are	still	meat

249	*	Ke	tIhotse	bana
		Pro	Aux.V	N
		I	have been	children

Thus examples (248) and (249) above cannot be regarded as well-formed sentences simply because they have not been used with basic verbal constructions as part of their sub-distribution.

- (b) Auxiliary verbs cannot take modifiers as verbs do. This is illustrated in the examples given below - (250) and (251):

250. \*      Ke      tIhotse      thata  
          Pro      Aux.V      ADV  
          I      have been much

251. \*      Ke      ntse      gagolo  
          Pro      Aux.V      ADV  
          I      am still much

Examples (250) and (251) above are ill-formed because the auxiliary verbs are not followed by basic verbal constructions.

(c) Auxiliary verbs must take complements which are primarily sentential/clausal. This is illustrated in examples (252) and (253) below:

252.           Ke      tIhotse      ke      tshameka  
          Pro      Aux.V      Pro      V  
          I      have      been      playing

253.           Ke      ntse      ke      robetse  
          Pro      Aux.V      Pro      V  
          I      have      been      sleeping

In this way, the auxiliary verbs are used with basic verbal constructions in a sentence thus yielding well-formed sentences. We shall now analyze the complements of various auxiliary verbs.

It is worth noting that auxiliary verbs get their grammaticality from the fact that they function in a sentence together with basic verbal constructions. Thus the complements of auxiliary verbs are primarily sentential/clausal complements as it is stated in point (c) above. The following tree diagrams in (254) and (255) below further illustrate this point and they represent examples (252) and (253) above respectively:

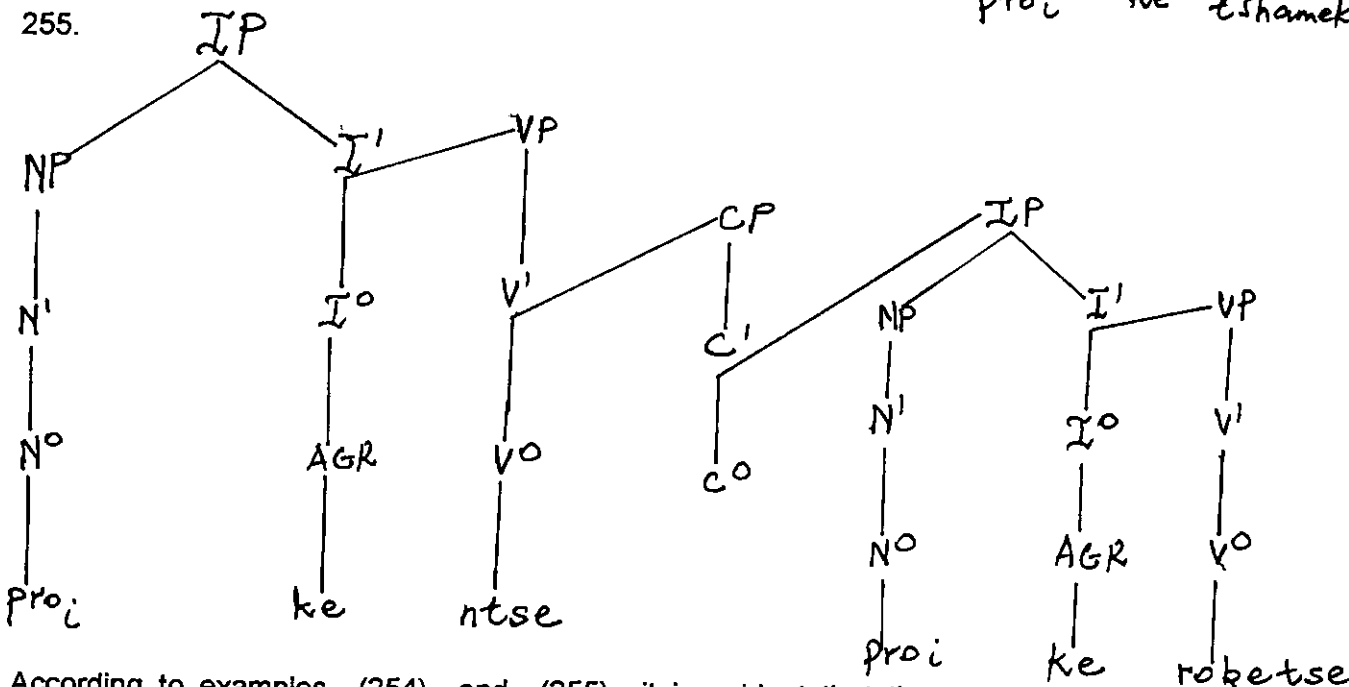
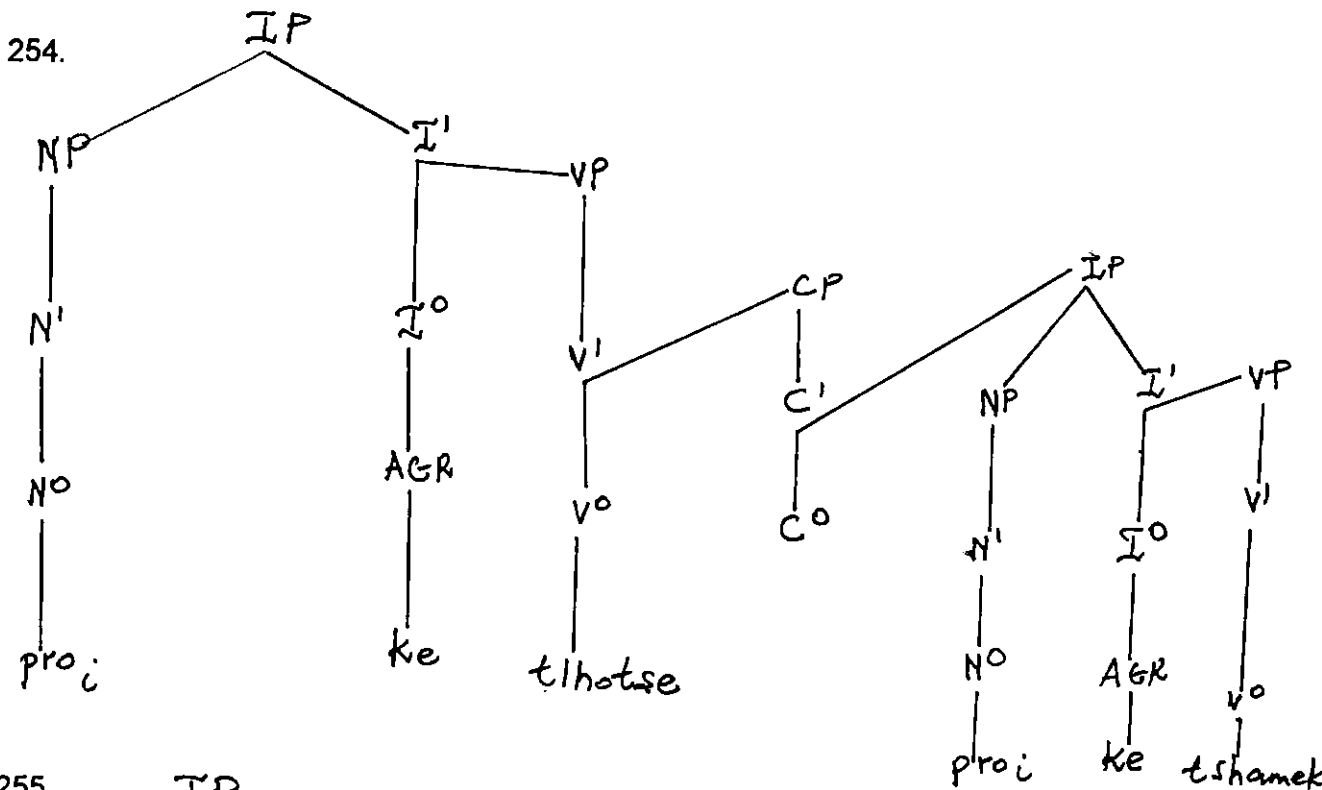

According to examples (254) and (255) it is evident that the auxiliary verbs subcategorize for a CP complement as well as an IP complement. A question that needs to be raised at this stage is why auxiliary verbs subcategorize for CP and IP complements and not other types of complements e.g. NPs? The reason for this strict subcategorization is because the auxiliary verbs are not lexical constituents but rather they are grammatical constituents which can only function with basic verbal constructions in a sentence. The other question that can be asked is why do we need a CP complement instead of just one complement, namely an IP complement?

A CP complement is there to stop the auxiliary verb from governing the small pro in the lower clause. This is so because if it is allowed to do so, then the small pro in the embedded clause will get two cases i.e. one accusative Case from the auxiliary verb in the matrix and one from INFL in the lower clause, thus violating the Case filter. (Having two cases is just as bad as having non at all). In this way, CP will act as barrier to government and consequently stopping the auxiliary verb from assigning Case.

Concerning the assignment of thematic-roles the following can be said about auxiliary verbs and that is they do not assign theta-roles (neither externally nor internally) and they can only depend on the basic verbal constructions in the lower clause to assign theta-roles. Auxiliary verbs are essentially grammatical and not lexical. The following tree diagram in example (256) below tries to summarize the subcategorization properties of auxiliary verbs in general:

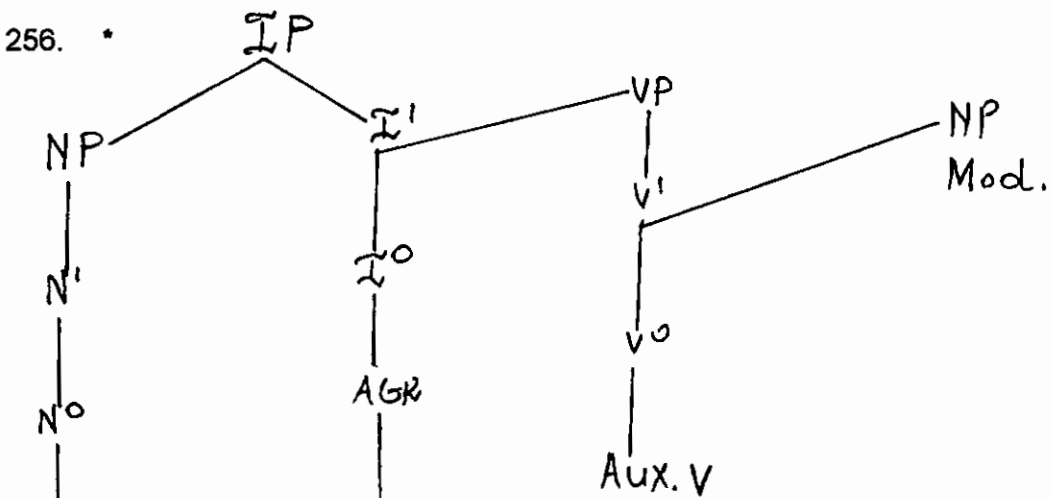

The following tree diagram illustrates the right/correct subcategorization properties of Auxiliary verbs:

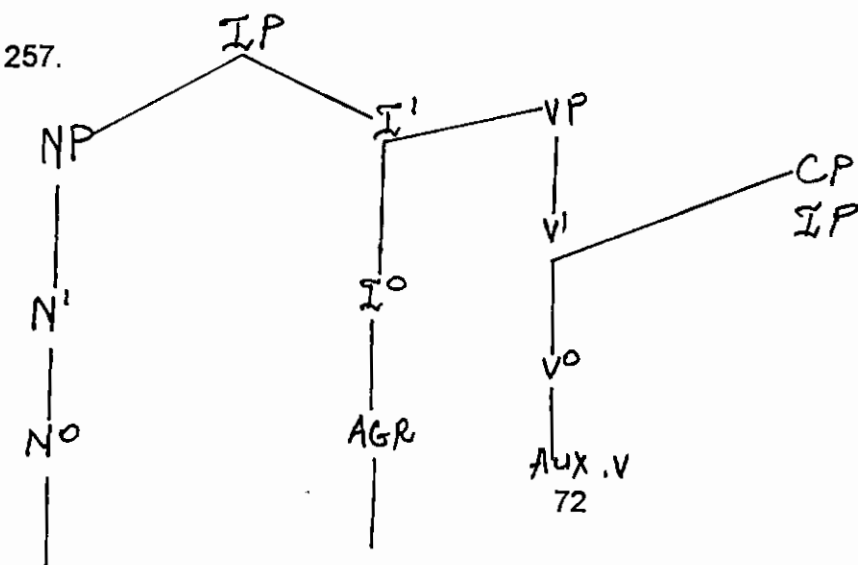

### 4.3 DEFICIENT VERB FORMS

We will now briefly discuss the subcategorization properties of the so-called deficient verb forms. Consider the following examples:

258.           Pule           a           ka           mmetsa  
                   N           AGR       DFV       V  
                   Pule           AGR       can       beat him/her

259.           Basimane    ba           sa           tsamaya  
                   N           AGR       DFV       V  
                   Boys           are       still       leaving

In examples (258) and (259) above the deficient verbs are used namely 'ka' and 'sa' respectively. Firstly, it is important to note that deficient verbs are somewhat similar to Auxiliary verbs in that they are also grammatical and not lexical. Thus they depend on the presence of the basic verb for them to function properly in a sentence. However, unlike Auxiliary verbs, deficient verbs do not subcategorize for clauses instead they subcategorize for basic verbs. Consider the following examples:

260. \*           Pule   'a       ka       gore   a       tsamaya  
                   N    AGR   DFV   C    AGR    V  
                   Pule   AGR   can   that   he   should leave

261 \*           Basimane    ba       sa       motho  
                   N           AGR    DFV    N  
                   Boys           are     still    person

Note that a basic verb is absent in both examples (260) and (261) hence both sentences are bad i.e. ungrammatical. In examples (258) and (259) above deficient verbs take basic verbs as their complements. This is a peculiar case where verbs can actually function as complements. Nevertheless, this does not mean that basic verbs themselves cannot subcategorize for complements when used in context with deficient verbs. Take a look at the following examples:

262.	Pule	a	ka	betsa	Motlalepule
	N	AGR	DFV	V	N
	Pule	AGR	can	beat	Motlalepule

263.	Mosidi	o	sa	tlhatswa	diaparo
	N	AGR	DFV	V	N
	Mosidi	is	still	washing	clothes

In examples (262) and (263) above the basic verbs *betsa* and *tlhatswa* subcategorize for NP despite the fact that they are also complements to deficient verbs. In the following section we discuss Copulatives.

#### 4.4 COPULATIVES

Copulatives are also verbal heads which subcategorize for various types of complements. As it will be shown, copulatives are in many respects different from basic verbs. In the following examples we illustrate a number of possible complements for copulatives.

264.	Rona	re	bahumi
	N	V	N
	We	are	rich people

265.	Nna	ke	nna,	wena	o	wena
	N	V	N	N	V	N
	I	am	myself,	you	are	yourself

266.	Nna	ké	yo,	wena	ó	yole
	N	V	Dem.	N	V	Dem
	I	am	this one,	you	are	that one

267.	Nna	ké	yo	moleele
	N	V	ADJ	
	I	am	the tall	one

268.            Rona            ré            basele  
                   N                V                ADJ  
                   We                are    the other ones

269.            Nna            ké            wa            gago,            mma  
                   N                V                ADJ                N  
                   I                am            yours,            mother

270.            Nna            ké            nosi  
                   N                V                ADJ  
                   I                am            alone

271.            Nna            ké            montle  
                   N                V                ADJ  
                   I                am            beautiful

In example (264) above the copulative *ke* subcategorizes for an NP, in example (265) the copulatives *ke* and *ó* subcategorize for Pronouns; in example (266) for a demonstrative; in example (267) for an adjective; in example (268) for an adjective; in example (269) the copulative subcategorizes for an adjective + an NP. In examples (270) and (271) the copulative still subcategorizes for an adjective. Consider the following tree diagram in examples (272) and (273) below:

272.            Rona            re            bahumi

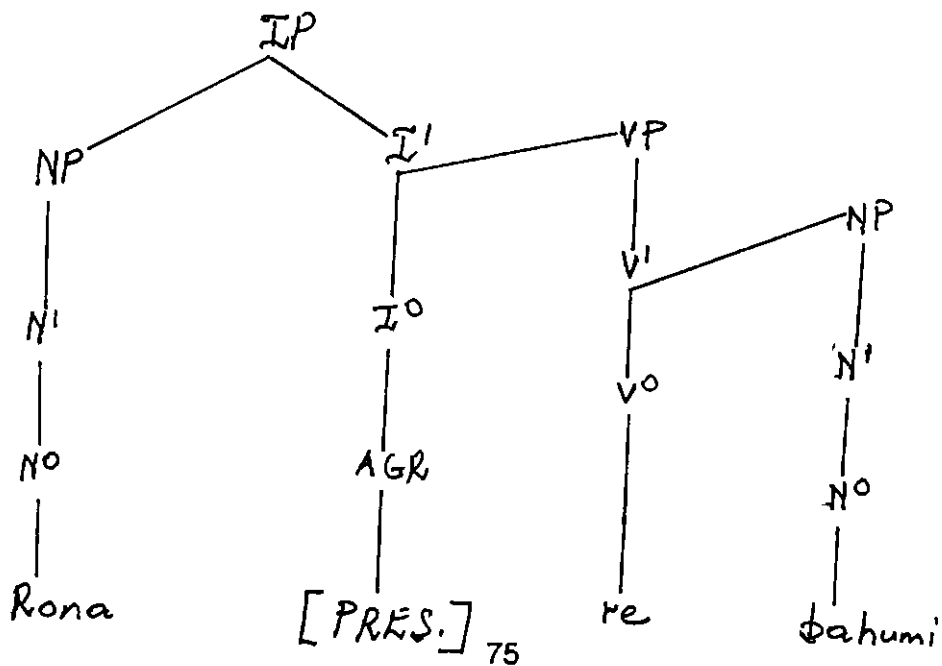

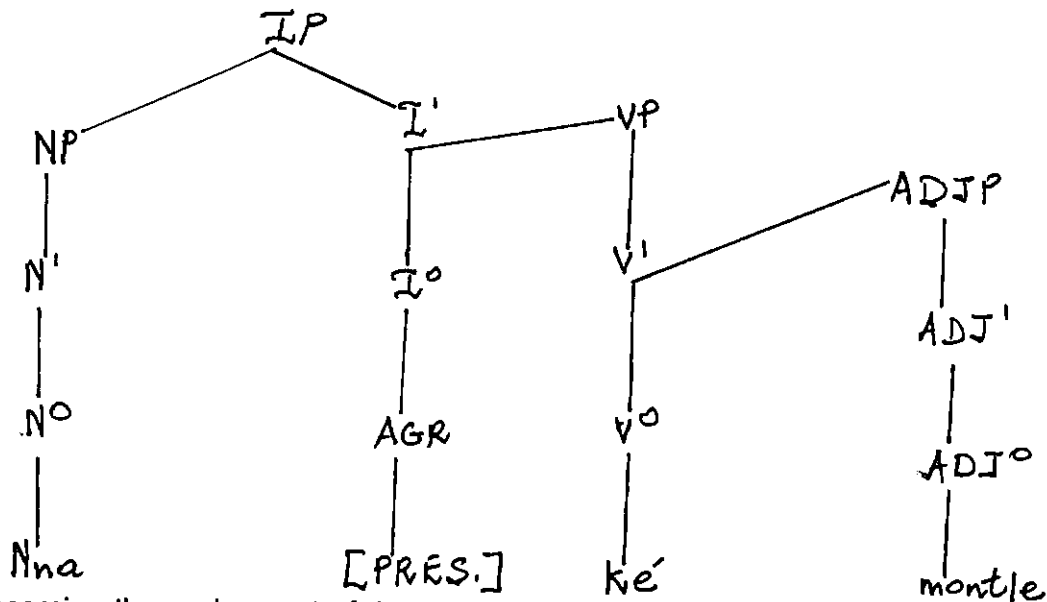

Concerning the assignment of thematic-roles it is evident that copulatives do assign theta-roles i.e. both the external  $\Theta$ -role and the internal  $\Theta$ -role. However, accusative Case can only be assigned in instances where the copulative subcategorizes for an object NP (as in example (264) above) because Case can only be assigned to NPs. Thus from there a copulative only remains a potential case assigner.

Copulatives can also subcategorize for NPs apart from Adjectives and demonstratives (as shown in examples cited above). Let us see some of the examples illustrating Copulatives subcategorizing for NPs:

274.	Nna	ke	na	le	batsadi
	N	AGR	V		N
	I	AGR	have		parents

275.	Mosadi	o	tla	nna	le	bana
	N	AGR	Pt	V		N
	A woman	AGR	will	have		children

Also consider tree diagrams in (276) and (277) below which represent (274) and (275) above respectively:

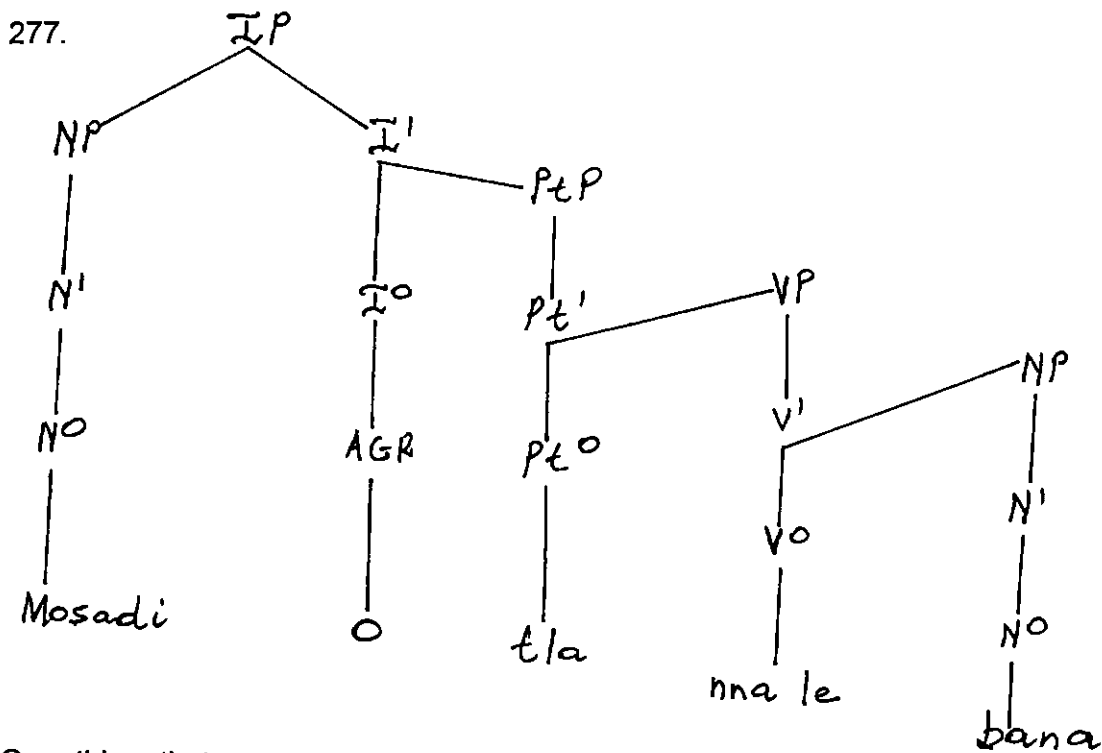
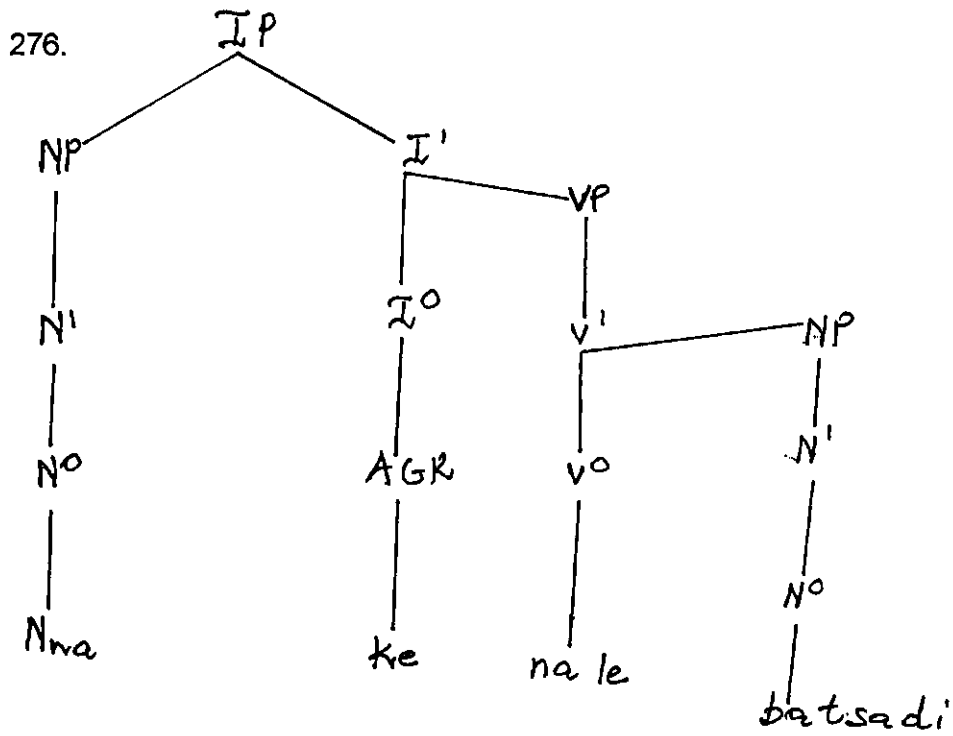

One thing that seems to be interesting about Copulatives is that they do not necessarily subcategorize for clauses. Take a look at the following examples:

278	*	Pule	ke	gore	a	tsamaya
		N	AGR	C	AGR	V
		Pule	is	that	he	should leave

279 \* Go nna le gore a tsamaye  
 Infin. V C AGR V  
 To be that he should leave

Apart from the examples cited above there are also rear cases where Copulatives can subcategorize for clauses. Look at example (280) below:

280. O na le gore a ka mmetsa  
 AGR V C AGR DFV V  
 He is capable of beating him.

## FOOTNOTES

1. Traditional terminology has been deliberately exploited in this dissertation to serve an expository purpose. Words such as 'object clitic' or 'object concord' do not have a linguistic bearing on our discussion.
2. The presence of an object clitic forces the inclusion of the a-element in the sentence. Take note of the following examples:

- (a)
- |        |     |       |          |
|--------|-----|-------|----------|
| Shoadi | o   | rata  | Setshego |
| N      | AGR | V     | N        |
| Shoadi | AGR | loves | Setshego |
- (b) \*
- |        |     |    |       |          |
|--------|-----|----|-------|----------|
| Shoadi | o   | mo | rata  | Setshego |
| N      | AGR | OC | V     | N        |
| Shoadi | AGR | OC | loves | Setshego |
- (c)
- |        |     |    |       |          |
|--------|-----|----|-------|----------|
| Shoadi | o a | mo | rata  | Setshego |
| N      | AGR | OC | V     | N        |
| Shoadi | AGR | OC | loves | Setshego |

Note that in example (b) above the absence of the a-element after the inclusion/addition of the object clitic *mo* leaves us with an ill-formed sentence. However, when the a-element is also included in example (c) above a well-formed sentence is yielded.

## CONCLUSION

All predictions of my hypotheses are borne out in Tswana. That is:

- (a) Different types of basic verbs accommodate different types of complements namely object NPs; sentential complements as well as ADJPs and ADVPs.
- (b) Basic verbs may be extended by means of affixes (extensions) which have the capacity to change the argument structure of verbs to which they are added.
- (c) Passive, Quasi-Passive and Reflexive morphemes are absorbers of Case.
- (d) Auxiliary verbs are grammatical and not lexical and they can only co-occur with basic verbs in sentences hence their accommodation of sentential complements.
- (e) Copulatives are verbal heads and they subcategorize for various types of complements.

Concentrating on the distribution of basic verbs in general I come to the following conclusion:

- Basic verbs signal that complements (clausal or NP) are sisters to the verbal head.
- A constituent receiving Case should always be P-governed, syntactically governed and adjacent to the Case assigning one.

## NOTES:

- In the case of the reflexive morpheme -i- the GB definition of the concept anaphore has been modified (in a way) to suit our discussion.
- The basic verbs i.e. verbal roots are actually underlying in Tswana. These morphemes attach other morphemes which are essentially grammatical namely verbal endings and verbal extensions.
- The morpheme -a in a-element is actually underlying but it surfaces as either ya or wa.
- The diacritic ' on a letter means high.

## BIBLIOGRAPHY

- BACH, E.W. 1974. Syntactic Theory. C.B.S. College Publishing: New York.
- BAUER, L. 1992. Introducing Linguistic Morphology, (first paper back edition). Edinburgh University Press: Edinburgh.
- BLOOMFIELD, L. 1970. Language. George Allen & Unwin Ltd: London.
- BROWN, E.K. and MILLER, J.E. 1980. Syntax (A Linguistic Introduction To Sentence Structure). Hutchinson and Company: London.
- CHOMSKY, N. 1981. Lectures on Government and Binding. Foris : Dordrecht.
- CHOMSKY, N. 1982. Some Concepts and Consequences of the Theory of Government and Binding. MIT Press : Cambridge, Mass.
- COLE, D.T. 1995 (1979). An Introduction to Tswana Grammar. Longman Penguin: Cape Town.
- DE GEEST, W. and PUTSEYS (eds.), Y. 1984. Sentential Complementation. Foris Publications : Dordrecht.
- DOKE, C.M. 1981. Textbook of Zulu Grammar. (Sixth edition eighth impression). Longman Penguin: Cape Town.
- DU PLESSIS, J.A. and VISSER, M. 1992. Xhosa Syntax. Via Afrika Limited : Pretoria.
- GAZDAR, G.; KLEIN, E.; PULLUM, G.K.; SAG, I. 1985. Generalised Phrase Structure Grammar. Harvard University Press : Cambridge, Mass.
- GUMA, S.M. 1971. An Outline Structure of Southern Sotho. Shuter and Shooter: Pietermaritzburg.
- HAEGEMAN, L.M.V. 1992. Introduction to Government and Binding theory. Blackwell : Oxford.
- HOEKSTRA, T. 1984. Transitivity (Grammatical Relations in Government - Binding Theory). Foris Publications: Dordrecht.
- KHOALI, B.T. 1993. 'The syntax of (ya) in Sotho'. S. Afr. J. A. Afr. Lang., 1, 1.
- KRUGER, C.J.H. 1994 'Notes on morphology with special reference to TSWANA'. S. Afr. S. Afr. Lang., 2, 15.
- LASNIK, H. and URIAGEREKA, J. 1988. A Course in GB Syntax (Lectures on Binding and Empty Categories). The MIT Press: Cambridge.

- LOUWRENS, L.J. 1991. Aspects of Northern Sotho Grammar. Via Afrika Limited: Pretoria.
- MATTHEWS, P.H. 1989. Morphology (An Introduction to the Theory of Word-Structure). Cambridge University Press: Cambridge.
- POSTHUMUS, L.C. 1994. 'Word-based versus root-based Morphology in the African Languages'. S.Afr. J. Afr. Language., 4, 28.
- RADFORD, A. 1988. Transformational Grammar (A First Course). Cambridge University Press: New York.
- RICHARDS, C.J.; PLATT, J.; PLATT, H. 1992. Dictionary of Language Teaching and Applied Linguistics. Longman Group UK Limited : England.
- SELLS, P. 1985. Lectures on Contemporary Theories. C.S.L.I: Stanford.
- SPENCER, A. 1991. Morphological Theory (An Introduction to Word-Structure in Generative Grammar). Basil Blackwell Ltd: Oxford.
- WASOW, T. 1979. Anaphora in generative grammar. Story-Scientia, Gent : Brussels.