

113907190

611011014

Φ10115432.

RELATIVE CLAUSES IN SESOTHO

by

MATSUANE FLORENCE LEEPILE

LP10
LEEP

Thesis submitted in accordance with the requirements
for the degree of Master of Arts

In the Department of African Languages

at

VISTA UNIVERSITY

Supervisor:
Date submitted:
Place:

Dr. B.T. Khoali
December, 1996
Vista (Bloemfontein Campus)



DEDICATION

This is dedicated to my husband Michael, our two daughters Sentle and BontLe, and our son Gontse, who wanted a graduate figure in the family.

ACKNOWLEDGEMENT

My first acknowledgement goes to my parents who were constantly encouraging me during hard times.

Acknowledgement and thanks should also go to my colleague Mmadiheshane with her encouraging words and has repeatedly read and commented on the draft of this thesis.

A debt of gratitude should also be extended to tireless typists Thandi and Soentjie who have patiently helped in the typing of this theses.

Above all, I owe a long standing debt to Dr. Khoali whose breadth of knowledge and commitment has long served to inspire my efforts.

DECLARATION

I declare that:

RELATIVE CLAUSES IN SESOTHO

is my own work, that all the sources used or quoted have been indicated and acknowledged by means of complete reference, and that this thesis was not previously submitted by me for a degree at another university.

TABLE OF CONTENTS

	Page
CHAPTER 1	
1 Introduction	1
1.1 Aim	1-3
1.2 Theoretical background	3-4
1.3 Review of literature	4-6
1.4 A summary of chapters	6
CHAPTER 2	
2.1 Introduction	7-9
2.2 Analysis	8-9
2.3 Direct relative clause	9-16
2.4 Conclusion	16-17
CHAPTER 3	
3.1 Introduction	18
3.2 Analysis	18-25
3.3 Conclusion	25
CHAPTER 4	
4.1 Introduction	26
4.2 Analysis	26-27
(a) Subjectival possessive relationship	27-28
(b) Plain objectival	28
(c) Adverbial	29
(d) Copulative relationship	29-31
4.3 Indirect relative clauses	31-46
4.4 Conclusion	46
CHAPTER 5	
5.1 Introduction	47
5.2 Analysis	47-61
5.3 Conclusion	62
Bibliography	63-65

SUMMARY

This dissertation has attempted to give an exposition of the structure of relative clauses in Sesotho. Firstly, we realized that the process of relativization displays the recursive nature of the Sesotho language wherein one sentence is embedded as a subordinate clause of another and by so doing an infinite number of clauses can then be implemented to qualify a Noun Phrase.

In the introduction I made it very clear that I will restrict myself to the view that in relative clauses a WH-word is moved from an argument position to Comp. I have demonstrated that Sesotho data does support this view. Where Sesotho data poses a bit of a problem is in the cases where traces are substituted by resumptive pronouns. I have not attempted to address theoretical problems presented by this because my aim is to demonstrate my understanding of the theory which I was taught in the Course-work lectures and to show that I can do research. I believe that I have achieved that which I had set to do within the scope of this dissertation. I have also not tried to argue against the view that clitics such as the reflexives and the object clitics are not anaphoric pronominals or non-anaphoric pronominals respectively. This is the view which I was taught during the lectures. It is supported by the relevant literature. I believe that it is possible that future work on these aspects might even prove this view untenable.

In conclusion I have observed that what the traditional grammarians, Cole (1955) and Doke and Mofokeng (1957) regard as the relative clauses of direct relationship and

indirect relationship involve movement of WH constituent from the argument position to Comp. An empty category is also created in the subject or whatever argument position when such movement takes place. Such an empty category always requires a proper governor to govern it.

I have also observed that sometimes when teng is used in the relative clause of indirect relationship, resumptive pronoun does not need to appear. Finally, I have noticed that when a compound tense is involved in a relative construction, it is the grammatical and not the lexical verb which seem to attract the relative suffix -ng. This is also in line with the C-command principle.

CHAPTER 1

1. INTRODUCTION

1.1 AIM

The main aim of this research is to provide an analysis of the relative clause constructions in Sesotho. I will attempt to give a somewhat idealized picture that is in part clearer in retrospect than it was in the past. Sesotho belongs to the Sotho language group. There are several dialects of Sesotho. The dialect which I will examine in this research paper is a dialect spoken in Botshabelo district east of Bloemfontein. Sotho languages belong to the South Eastern Zone of Bantu languages in Doke's classification of Bantu languages (Doke 1938). According to Guthrie's classification of Bantu languages, Sesotho is spoken in Zone S.S.30. It must also be borne in mind that I spent most of my life time among the Sesotho speaking people in the Free State in a small township of Morojaneng. Morojaneng is situated North west of Lesotho. Since Botshabelo is also situated north west of Lesotho, we can safely conclude that the dialect spoken in Botshabelo is the same as the one spoken in Morojaneng.

In examining Sesotho I will concentrate on complex sentences. A simple sentence and a compound one are not relevant in our analysis. In traditional grammar such as Doke and Mofokeng grammar of Sesotho such sentences are parsed and classified accordingly. Some sentences or clauses are said to be qualificative, some adverbial and others nominal. Doke and Mofokeng pay special attention to what they call relative clauses. Two such relative clauses are discussed. These are relative clauses of direct

relationship and relative clauses of indirect relationship. In this research I use Government and Binding theory to analyse such relative clauses.

As linguistic theory evolves, relative clause formation continues to be of interest to linguists. There seems to be universal principles for embedding clauses or sentences within the NP node across the board in languages of the world. This fact has serious theoretical implication for the development of theory in linguistics. Hence linguists have spent time analysing subordinate or embedded sentences. Within Government and Binding theory linguists call relative clauses WH- constructions. This emanates from the observation that relative clauses often involve WH-words. WH-words in Sesotho appear to be demonstratives of second position second set in Doke and Mofokeng's analysis. The boldfaced word in (1) below demonstrates such WH-words in Sesotho:

1. Mosadi eo batho ba mo lelekileng moketeng o kgutlile

Woman WHO people AGR OC chase+PERF+REL feast+LOC AGR return+PERF

The woman who has been chased away from the feast has returned

in general languages can be classified as being configurational and non-configurational. Sesotho is a configurational language. Certain words occupy certain positions. Doke and Mofokeng identified six such positions: substantive position, qualificative position, predicative position, descriptive position, conjunctive position and interjective position (Doke and Mofokeng 1957). In short, Doke and Mofokeng also acknowledge the fact that Sesotho is configurational. Word order type for the language is an SVO one. In other words, the subject normally precedes the verb and the verb in turn precedes the object. When a sentence in Sesotho expands by embedding, such embedded sentences will

normally follow the head noun. Hence, we can conclude that Sesotho is a right-branching configurational language. Tree diagrams which will be demonstrated in this research will also confirm that Sesotho is a right-branching configurational language.

1.2 THEORETICAL BACKGROUND

Within Government and Binding theory specific principles such as Projection Principle, Subjacency, X-bar scheme, theta criterion, move alpha and case filter will be employed in analysing Sesotho sentences (Sells, 1985). Context for lexical items is projected in the lexicon. Hence, such context may not be ignored in all representations. The projection principle is meant to rule out representations that violate the subcategorisation frames of lexical items. Domain of operation is often delimited in Government and Binding. Hence, the principle of subjacency plays a crucial role in movement transformations. The template which befits the subcategorisation frame of lexical items is the X-bar scheme. The scheme defines positions which can be occupied relative to the head of phrase: a complement, a modifier and a specifier. Theta criterion which allows only one argument for one theta role and one theta for one argument will be used (Chomsky 1986: 84). The application of the rule Move alpha which moves constituents from theta position to theta-bar position will be explored. When movement takes place, traces are created. Such traces need to be properly governed as is demanded by the Empty Category Principle. The case filter will determine the grammaticality of NPs at S-structure. In this case chains are expected to have only one case because having more than one case is as bad as having none at all. The extended projection principle which requires that all clauses should have subjects will also be explored.

1.3 REVIEW OF LITERATURE

In Sesotho, very little of research has been done on relative clauses. Scholars such as Cole, Doke and Mofokeng paid some attention to the relative clauses in Sesotho. Since these scholars were aiming at providing a complete description of the languages in order to reduce them into effective writing, much of what Government and Binding theory can reveal about relative clauses could not be exposed. These grammarians merely refer to the relative clauses in passing when discussing the classification of words into parts of speech.

According to (Cole 1955) there are six types of clauses or words which can function to qualify the substantive. Among these six clauses which are known as qualificatives, simply because they qualify the substantive, is the relative as in 2 and 3 below:

2. Mosadi ya tsamayang o jele
Woman Conc V + REL AGR V (PERF)
A travelling woman has eaten

3. Lehare le botswa le wele
Razor Conc REL AGR V (PERF)
A blunt razor has fallen

In 2 and 3, mosadi and lehare are words which the traditional grammarians call the substantives. This is so because in 2, mosadi is the subject of the sentence. In addition, in 2 and 3 above the underlined ya tsamayang and le botswa are regarded as relative

words. This goes without saying that ya tsámayang and le botswa have an equal status in traditional grammar (Doke and Mofokeng 1957:423).

Furthermore, traditional grammarians analyse the structure of such relative words as the gloss in 2 and 3 above illustrates. In GB a representation of sentence 2 reveals clearly that ya tsamayang is an embedded sentence which has the subject NP e moved to Comp. The relativiser ng is also attached to the verb tsamaya. Sentence 3 in GB shows that le botswa is not an embedded sentence. It is attributive in nature and therefore is a particle phrase with an AP embedded in it. There is thus a big and clear difference between a GB analysis and a traditional analysis. Hence the need to analyse relative clause formation in Sesotho is overdue.

A thesis on relativization exploring generative grammar has been filed. Vitale analyses relative clauses in Swahili using the earlier version of generative grammar (Vitale 1967). The surface structure is arrived at through more than one transformational rule. In GB, i.e. the theory I explore in this research, however, there is only one transformational rule namely, move alpha. In Vitale's thesis a number of transformational rules are employed to arrive at the surface structure. There is thus a difference between Vitale's analysis of Swahili relativization and our analysis of Sesotho relativization. Including Cole in our analysis should not cause confusion because Setswana and Sesotho, our present data, all belong to the Sotho group in Guthrie's classification of Bantu languages.

It must be borne in mind that the brief review of the main features and weaknesses of the

traditional grammarians' model given in this introduction is not intended to underrate or undermine the Doke and Mofokeng's great contribution to the Bantu linguistic studies.

Doke and Mofokeng 's work have been of the greatest significance in stimulating analysis and descriptions by other Bantu linguistic scholars. This goes without saying that there is no doubt about the model of description developed by these two grammarians for the fact that their contributions in the Bantu linguistic studies has served to greatly upgrade the standard of Bantu linguistics in Southern Africa and elsewhere.

1.4 A SUMMARY OF CHAPTERS

This dissertation is divided into six chapters. Chapter one is an overview. The aim , the theory, review of the literature and a summary of the chapters are discussed. Analysis of the elements of relative clauses particularly the relative clauses of direct relationship are the focus of chapter two. In chapter three, we hypothesise that there is a movement transformation that operates in relative clauses and that the WH particle moves by move alpha to Comp. The importance of subcategorisation is also explained. The c-command principle is explored in depth in chapter four. Auxiliary verbs are also analysed with an eye on whether they attract the relativiser ng or not. Finally, chapter five provides direct evidence that a preposition is a proper governor in Sesotho. This chapter also focuses on the fact that after the movement has applied the empty category can be occupied by the resumptive pronoun in Sesotho. Chapter six is a brief summary of the whole dissertation.

CHAPTER 2

2.1 INTRODUCTION

This chapter will review the analysis of relative clauses by traditional grammarians. Relative clauses will be explained in detail using Government and Binding Theory. Much emphasis will be put on the relative clause of direct relationship.

According to Doke and Mofokeng (1957:421-422), there are two types of relative clauses in Sesotho as in Bantu generally, namely direct and indirect clause. Generally it may be said that direct relative clauses are those in which the concord used in the clause as subject is in agreement with the antecedent.

4. Monna (ya shapang bana) o fihlile
man Comp AGR beat+REL children AGR arrive+PERF
The man who beats up children has arrived

In 4 above monna is an antecedent. This antecedent is coreferential with the subject of the relative clause. The relative concord ya agreeing with the antecedent is prefixed to the verb. The verb which is basically participial, in most cases assumes the relativiser -ng.

When the predicate is multiverbal, the relative concord is prefixed to the first verb (a deficient) only, which is also the only verb to assume the relativiser -ng

(Doke and Mofokeng 1957:422).

5. Leihlo [le ileng la bona ntwā] le kgathetse

eye Comp AGR AUX+REL AGR see war AGR tire+PERF

The eye that has seen war is tired

In 5 above the predicate is multiverbal. It consists of the auxiliary verb ile and the main verb bona. The relativiser -ng is suffixed to the auxiliary verb ile.

2.2 ANALYSIS

Studies on the relative clauses in Sesotho have hitherto been conceived within traditional grammar. This means that words, clauses or phrases are classified into parts of speech. Words or clauses which qualify the substantive are six (Cole 1955). Among these six qualificatives is the relative as in 6 and 7.

6. Ngwanana ya bohale o llile

Girl Conc fierce AGR cry+PERF

A fierce girl has cried

7. Mosadi [ya buang] o buile

Woman Comp AGR speak+REL AGR speak+PERF

A woman who speaks has spoken

As I indicated earlier, ngwanana and mosadi in 6 and 7 are words which traditional

grammarians call the substantive. This is so because they are the subjects of matrix sentences. In addition ya bohale and ya buang are regarded as relative words. Furthermore, since Sesotho is a pro-drop language, ngwanana and mosadi may be omitted in a sentence. In this regard ya bohale and ya buang refer to the omitted substantives meaning that they qualify the substantives. These clauses ya bohale and ya buang do have an equal status in traditional grammar. In GB these clauses do not have an equal status. Ya bohale is a particle phrase embedding an AP while ya buang, on the other hand, is a sentence embedded in a NP. In Khoali (1991) particle phrases are well motivated (Khoali 1991). A phrase headed by a non-verbal non-nominal non-case marking is a particle phrase. There is tonological evidence to advance the existence of such a category.

2.3 DIRECT RELATIVE CLAUSE

Diagram 8 below illustrates the hierarchical organisation of sentence 8. The diagram shows that the head lesole is modified by a CP le buang. The CP is headed by C which c-commands IP. The subject NP of IP is a trace. The AGR is a le which has fused with comp le. Evidence is clearly demonstrable in Setswana where the two le's are not fused. We should recall that Setswana and Sesotho are closely related. The sentence would read as lesole le le buang le nole in Setswana. In short, the head of CP is specified as WH. The feature then percolates to the mother node. There are some conventions that actually guarantee such percolation is constrained. What is crucial for our research is the fact that the demonstrative of second position second set is in fact a WH-word. There are other considerations that prove that these demonstratives are WH-words. One such evidence is the fact that these are the only demonstratives that are

used in questioning in Sesotho. In addition, there is compelling tonological evidence to support this view (see Khoali 1991). I will not indulge in details in this regard. Diagram 8 is enough to illustrate that Move alpha has applied and moved the WH-word from the subject position to Comp.

8. Lesole le buang le nwele

NP c v AGR v

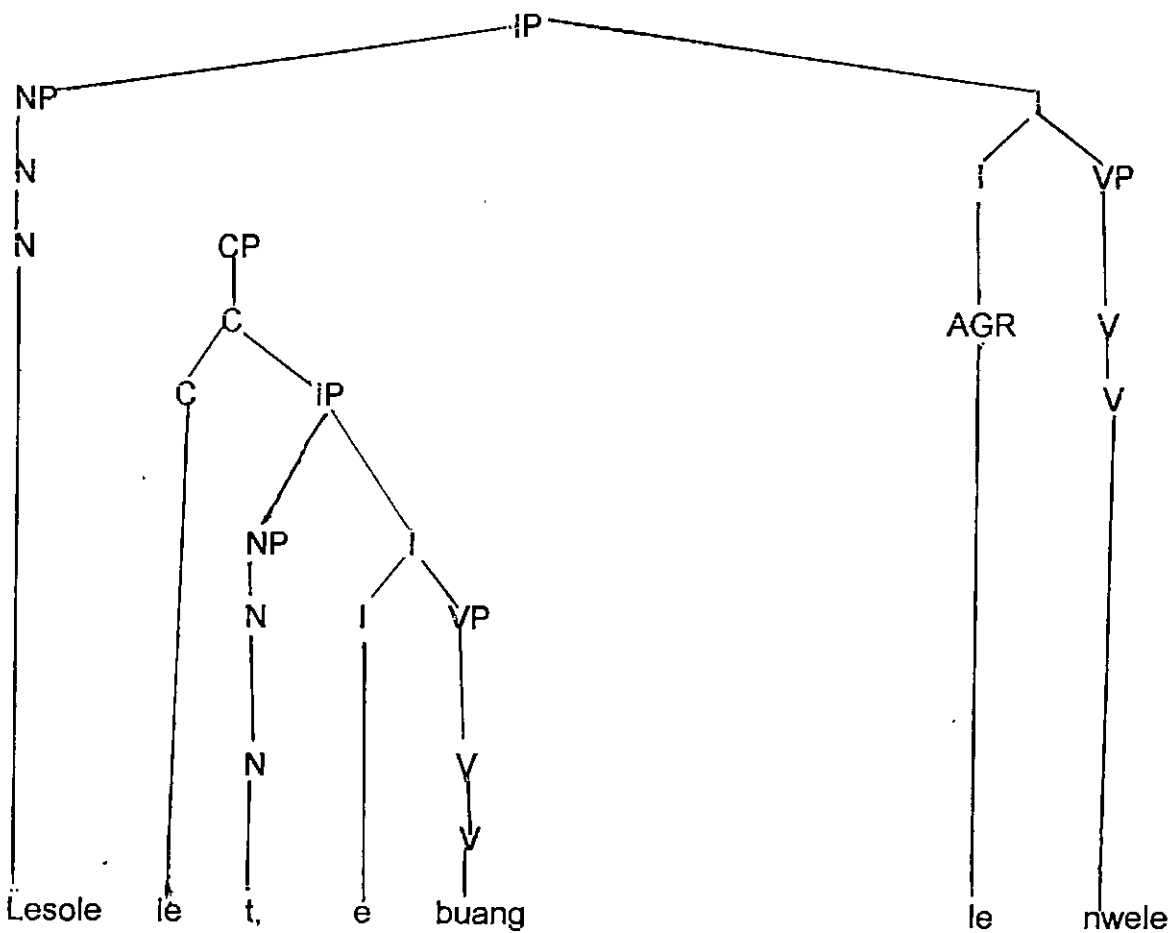

Ignoring the part of the derivation concerned with the VP of the IP, the derivation will proceed as follows: In the D-structure, there is a relative pronoun or a WH-word le in the argument position which is the head of relative clause le buang. This WH-word is

moved to Comp and thereby leaving a trace. This trace is a WH-trace and is properly governed as is demanded by the ECP (Empty Category Principle). When this movement takes place, a relativiser -ng is suffixed to the relative verb. It will not be my preoccupation to argue about the role morphology is playing in this regard. I will just assume an organisation of grammar which allows morphological operations to interact with syntactic operations. It is therefore assumed that the boundary between morphology and syntax is not as discernible as it used to be in earlier transformation generative grammar.

We also observe that there is an agreement le in 8, unlike in 9 below:

9. D: Monna (ea mobe) o fihlile

S: Monna ya mobe o fihlile

NP Rel Conc Adj AGR V

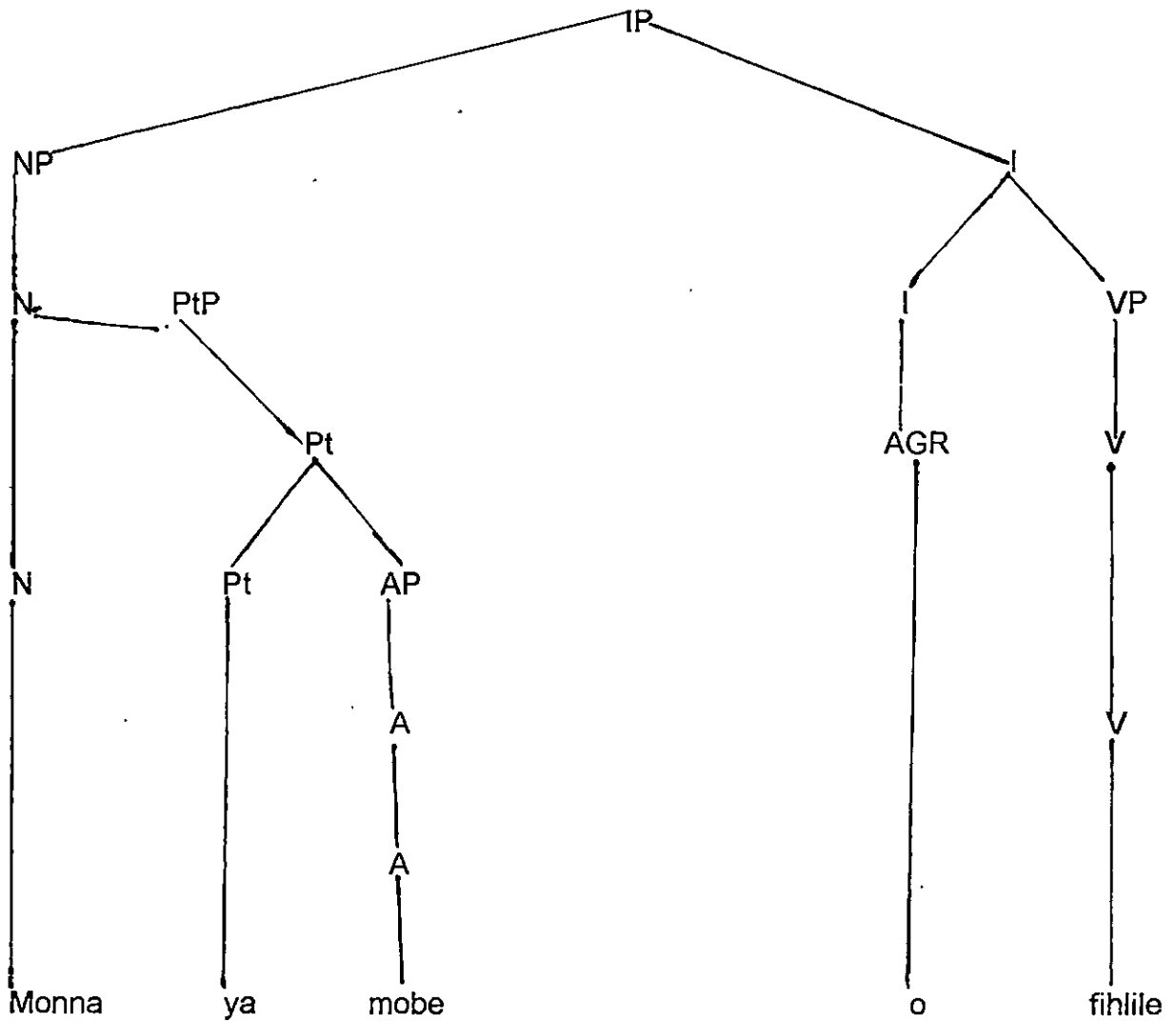

projection principle and theta criterion. Diagram 11 illustrates this succinctly:

11.

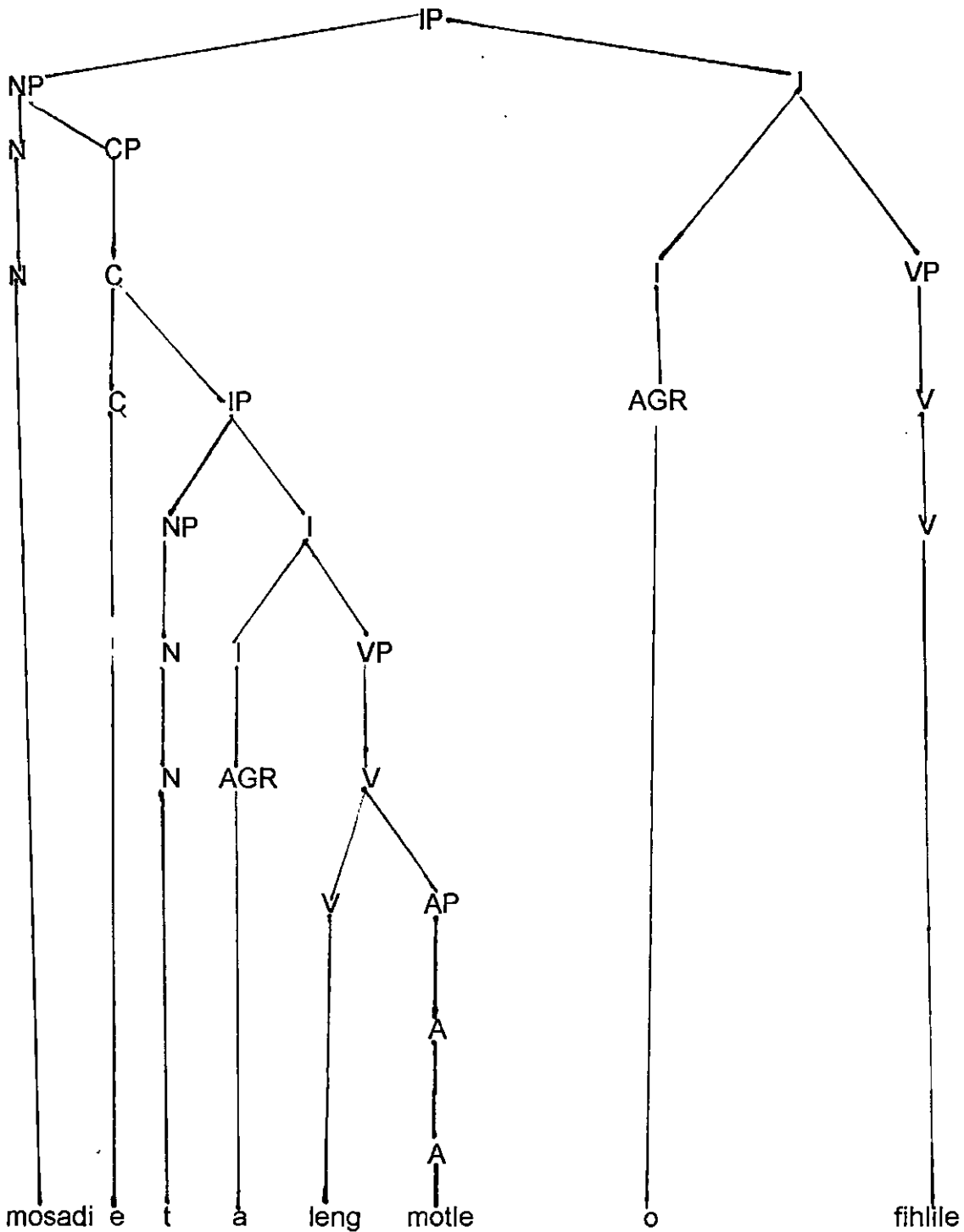

The difference between (9) and (11) is that, the copula leng in 11 subcategories for an AP (adjective). The ng is attached to the verb le. In 9 the ya is just a particle head.

Another example is in 12, where the negative form is used.

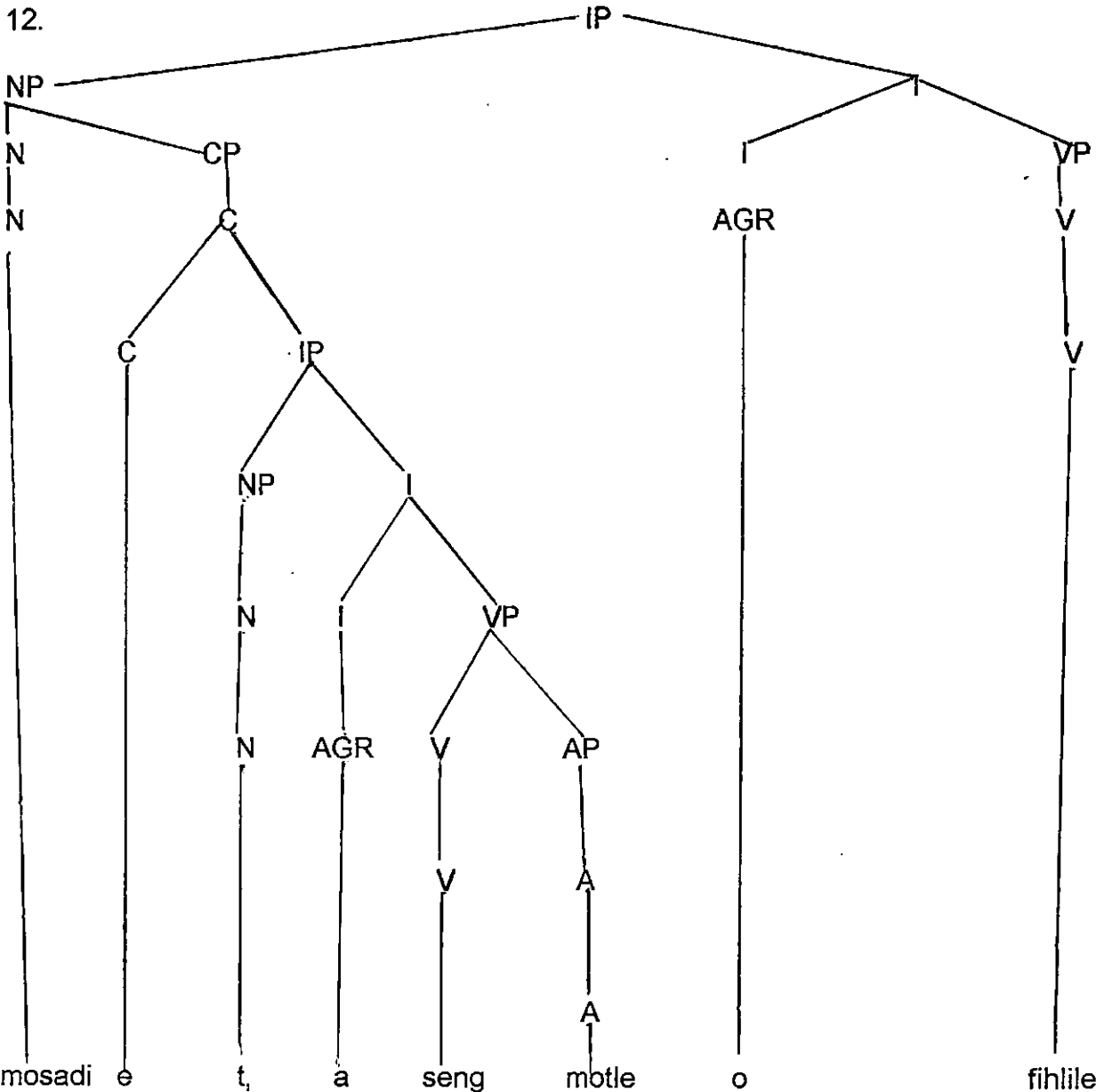

In (12) the suffix -ng is attached to the negative V se. Note that the se which is a copula for the negative adjective, becomes the target for the attachment of the relativiser -ng. Traditional grammar does not reveal that a higher V attracts the relativiser. The same applies when the copula ne or ba is used as in 13 below:

13. (a) Motho ya neng a bua o thatse
 person Comp+AGR AUX+REL AGR speak AGR quiet The person who

was speaking is quiet

(b) Ngwana ya bang molelele o mametse

person Comp+AGR AUX+REL tall AGR listen+PERF

The child who is becoming tall is listening

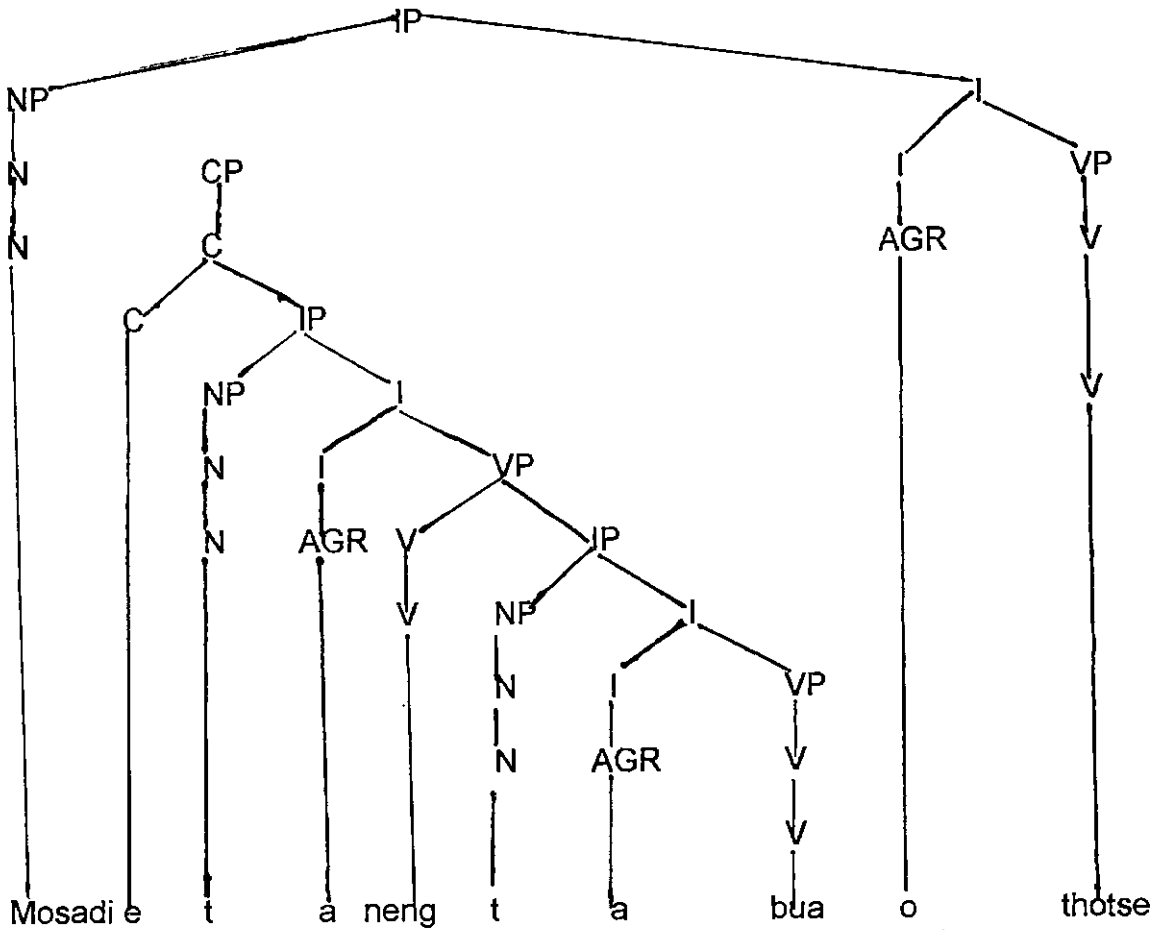

In 13 we observe that the suffix -ng is attached to the auxiliary verb instead of attaching it to the verb.

CONCLUSION

In the light of the above presentation we can conclude that in Sesotho it is the auxiliary

verb and not the principal verb which becomes the target for the WH-element. We could have assumed that in Sesotho there is no application of Move alpha. With this view we would have assumed that each Comp is base-generated (see Bennis & Haegeman 1984, Harlow 1982, Rittner 1995 and Lebeaux 1991). This study is intended to demonstrate ability to do research within the limited space and time allowed. Hence, we have opted to ignore all other views and have concentrated on a widely known view, namely relativisation involving WH-word movement. If one were to pursue these issues at a doctoral level, one would have both time and scope to demonstrate the power of each view over the other. For the purposes of a limited Course-work Masters degree, the safest route is to restrict oneself to a well known view.

CHAPTER 3

3.1 INTRODUCTION

In chapter 2 relative clauses of direct relationship have been discussed. Types of such relative clauses were analysed. These involved relative clauses with multi-verbal predicates. We demonstrated that the relativiser is always on the higher predicate. In this chapter we explore relative clauses of direct relationship. In other words, this chapter is a mere expansion of chapter 2.

3.2 ANALYSIS

I will begin my expansion by demonstrating the hierarchical organisation of a sentence involving a relative clause of direct relationship as in 14 below:

14.

D: Mosadi (comp) ya robalang o tsamaile

S: Mosadi ya robalang o tsamaile

NP Con V AGR V

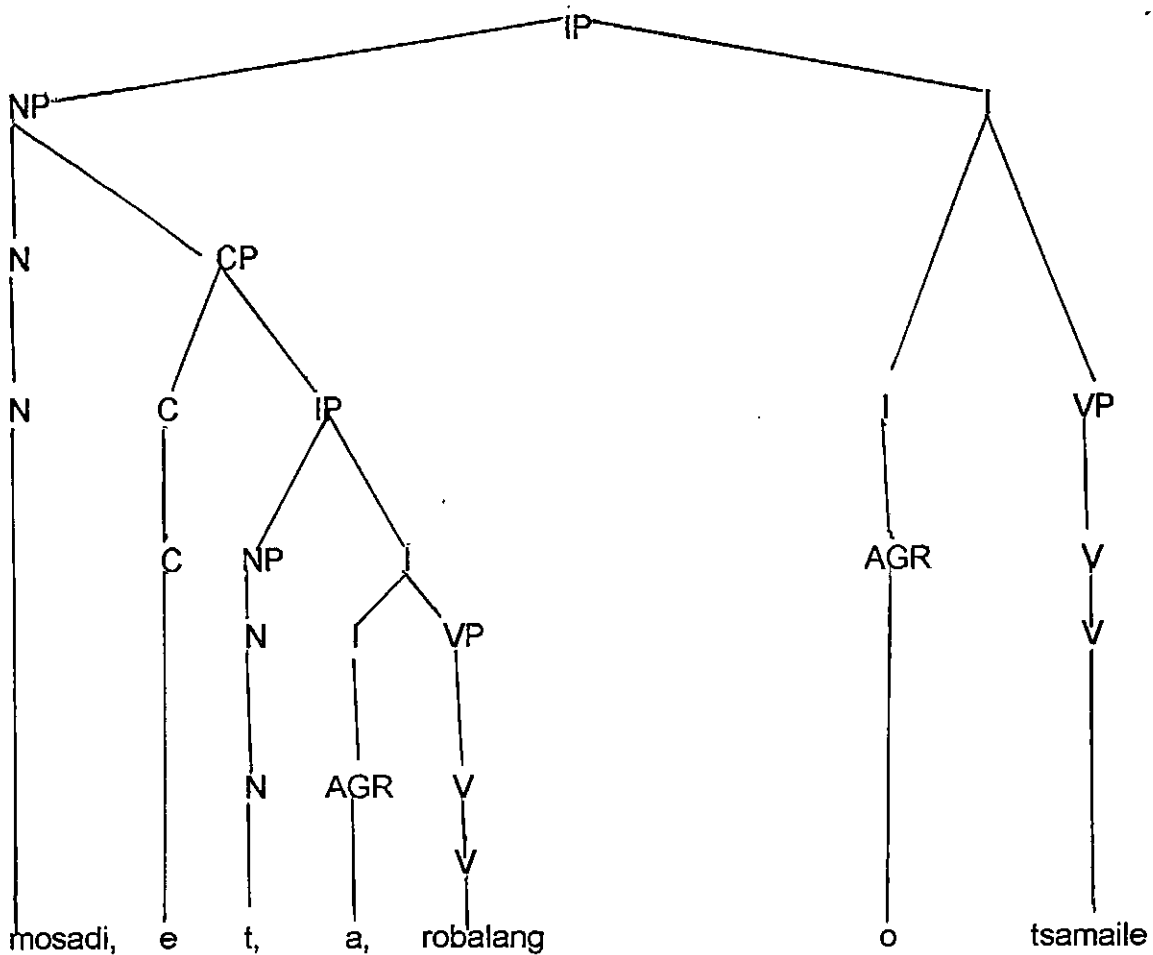

In 14 above, move alpha has moved e from an argument position in the D-Structure to an A-bar position at S-structure. The empty category is left behind. The relationship between the subject NP, empty category and agreement is indicated by co-indexing. Therefore, move alpha and the projection principle will ensure that all A-positions at S-structure receive an index. The WH-trace has the same index as the Comp. The Empty

Category Principle requires that the empty category to be properly governed. Therefore, since lexical items are the proper governors for traces, we expect the subject position in 14 above not to be properly governed. INFL is not a lexical item and therefore cannot be a proper governor for such traces (see Sells 1985). Hlekang is a relative verb but unfortunately it cannot govern the empty category because it is not in the same domain as the empty category. The WH-word in Comp is a lexical item and c-commands the trace. The WH-word therefore governs the trace. This is in line with the second clause of proper government (see Sells 1985). The relativiser hops from the lower VP to the higher V as is the case in (15) below.

15. D: Monna (comp) ya yeng a robale o hlokahetse

S: Monna ya yeng a robale () o hlokahetse

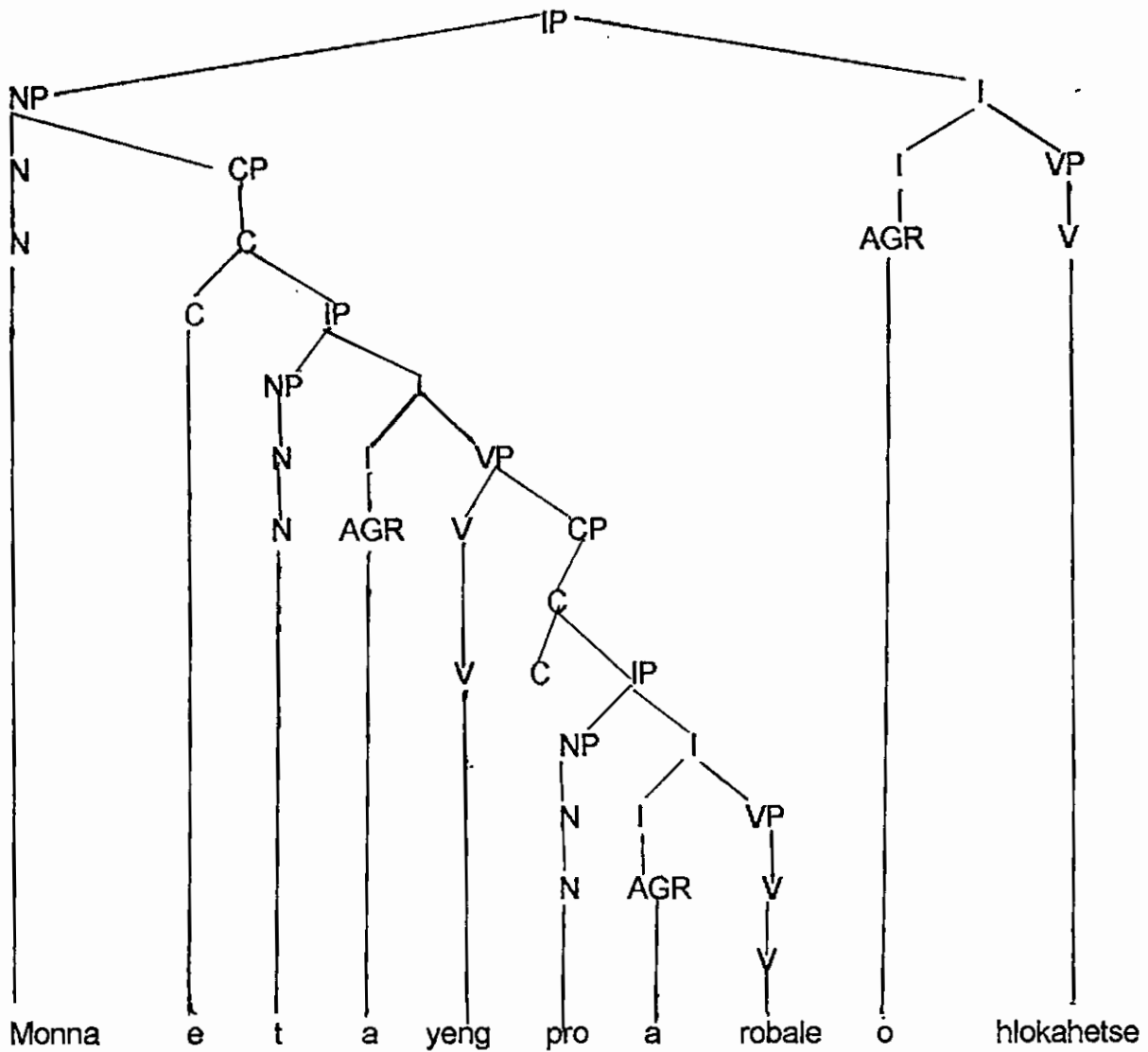

The deficient verb ye indicates that the action takes place usually as a matter of habit or regular custom. It is interesting to note that the agreement a is often retained in the relative construction, as in (15). Secondly when the deficient stem ye is used in the ordinary participial construction, there is no attachment of the -ng to it as in Monna o ye a robale. In the case of a relative clause, the -ng which could have been attached to the complement verb is attached to the deficient verb stem ye. This movement from a thematic head to a functional

head is called head-to-head movement by Travis (Travis 1980).

16.

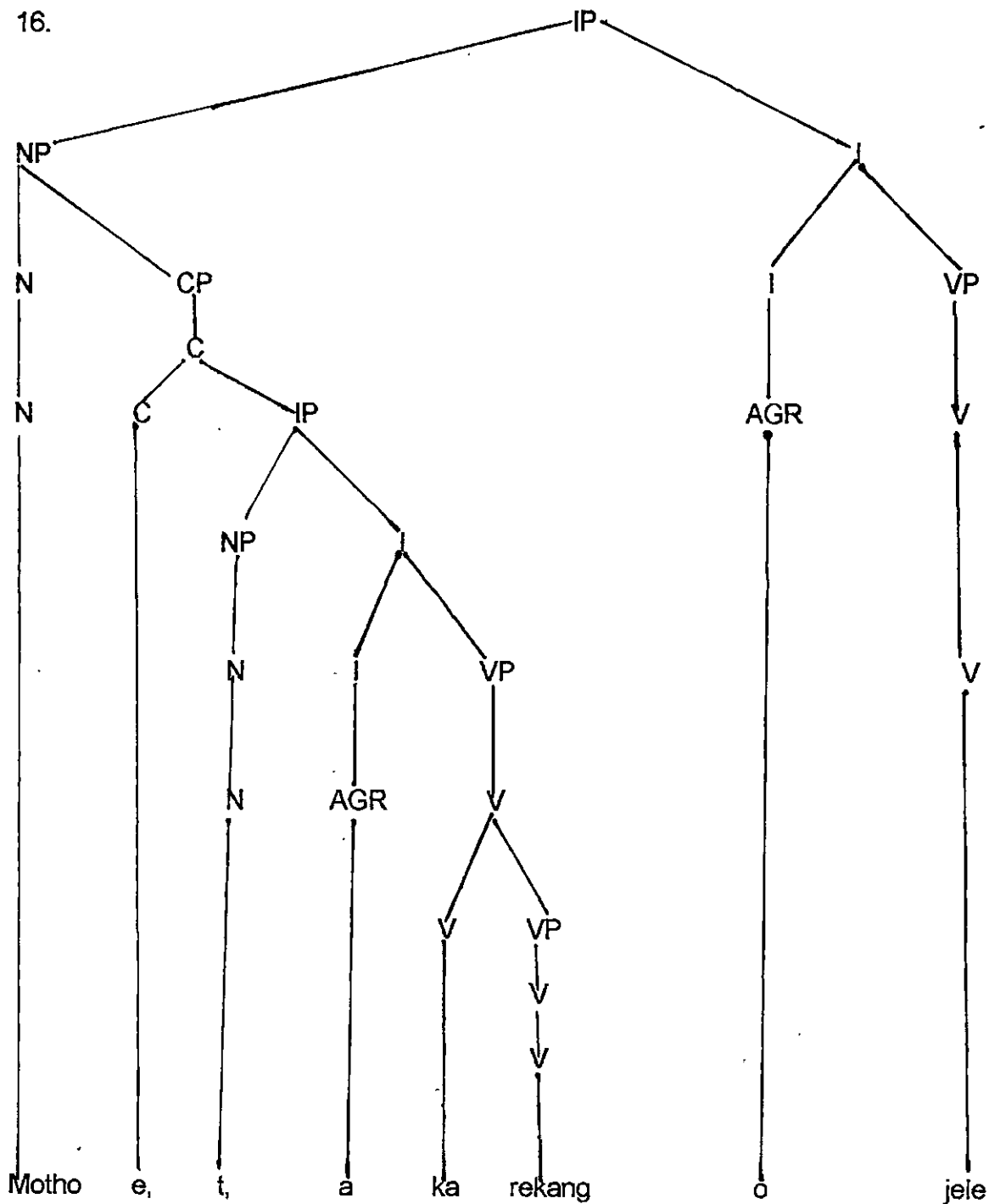

The ka in 16 is used as a potential marker. It does not attract the relativiser -ng. We have seen how auxiliaries such as ntse, ye, ba, etc.) attract the relativiser. Ka is therefore unmarked for relativiser attraction. Traditional grammarians maintain that ka is

auxiliaries. Auxiliaries do have that tendency of attracting the relative suffix -ng which the potential marker ka and the negative marker se cannot do.

In 18 below, we show that relative clauses display the recursivity nature of the Sesotho language. There is just no limit to the number of relative clauses that can qualify the head noun.

18. Mosadi ya nonneng ya bohale ya molele o a lla
NP C OBESE C FIERCE C TALL AGR CRY
An obese fierce tall woman is crying

In 18 there can be an infinite number of relative clauses modifying the head noun mosadi. Recursion thus permits embedding in grammar.

Now the question is: How is movement applied in 18? In this case we are dealing with the constraints on the application of move-alpha (see Lasnik and Uriagereka, 1988:96). Subjacency island constraints provide such restrictions by requiring that each application of move alpha should not operate over a large distance i.e. movement out of a clause within an NP is not permitted. But move alpha may iterate so that the movement is a series of small hops. This movement is termed successive cyclic for the fact that instead of moving a WH phrase from A-position all the way up to its S-structure position in one fell swoop, we first move it the lower Comp, and from that Comp to the next higher Comp and so forth as in 19 below.

NP

NP

NP

NP

3.3 CONCLUSION

The negative marker se and the potential marker ka are not auxiliaries in GB. The reason being that they neither behave like auxiliaries nor show common characteristics found in auxiliaries. In this chapter, I tested all auxiliaries and they mostly tend to attract the relative suffix ng. But both the negative and the potential markers do not license the suffixation of ng to them.

The behaviour of the negative and the potential lexical items creates a problem for our derivations. A representation which shows the negative and the potential in a specifier position of the lexical head V appears convincing because it would be a confirmation that ka and se do not subcategorise for phrasal elements. This seems to suggest that my earlier statement that ka subcategorises for a VP is flawed. Ka and se are mere specifiers to verbal heads.

CHAPTER 4

4.1 INTRODUCTION

This chapter will focus on the relative clause construction of indirect relationships. Firstly, I will endeavour to give a brief analysis of indirect relative clauses as seen by traditional grammarians. The leading figures in this traditional grammar analysis are Doke and Mofokeng. A brief review of Vitale's analysis will also be given. Vitale's analysis was based on the Extended Standard theory. A number of transformational rules characterise that analysis. Vitale's analysis is relevant to our research because he analysed Swahili, a Bantu language.

4.2 ANALYSIS

Generally relative clauses of indirect relationship are characterised by the fact that the subject of the relative is not the same as the antecedent. The antecedent can bear any other relationship other than the subjectival relationship. The antecedent is, however, referred to by means of a demonstrative pronoun which agrees with it. This is usually a demonstrative of the second position (eo, bao, etc.) (Doke and Mofokeng, 1967:423-424). We should recall that the demonstrative pronoun is what is called a WH-word in chapter 2 and 3.

In Motho eo ba mo shapileng o shwele, [eo ba mo shapileng] is a relative clause. This is so because, it qualifies the substantive which is in this case motho (a person). This relative construction is introduced by a demonstrative pronoun eo. The NP motho is the subject of the matrix clause containing the predicate o shwele (has died). This NP subject

is brought into concordial agreement with the verb shwele by an agreement o. The relative verb is characterised by a relativiser -ng as in shapileng. This is in line with the general rule of the indirect relative construction which requires that the verb stem in simple tense assumes the relative suffix -ng.

According to Doke and Mofokeng (1967:424-429) the relative construction of indirect relationship has four different categories namely:

- (a) Subjectival possessive relationship
- (b) Objectival
- (c) Adverbial
- (d) Copulative

(a) Subjectival possessive relationship

In the subjectival possessive relationship, we notice that the antecedent possesses the subject NP of the relative clause as in 21 below.

21. Morena [eo setjhaba sa hae se lwanneng] o buile

In 21 Morena is the antecedent. Eo is the Demonstrative. Setjhaba is a Noun Subject of the embedded clause. Sa is a possessive concord. Hae is possessive pronoun coreferential with the antecedent. Se is the subjectival concord agreeing with the Noun Subject. Shweleng is the relative verb with a relativiser -ng.

(b) Plain objectival

This kind of indirect relative construction is employed where for instance the antecedent is seen as the object of the relative predicate. In 22 below bana is the antecedent and is coreferential with the object NP of the relative verb hodisang.

22. Bana (bao re ba hodisang) ba tsamaile.

Children WH+word pro AGR them grow AGR go+PERF

Children we nurtured have left

In 22 bana is coreferential with the incorporated NP ba. Ba is an object clitic. Ba leans on the verb. According to Matthews clitics are midway between full words and morphemes (Matthews 1981). In other words, a clitic can be a head of an NP since it is nominal and non-verbal. In 22 bao is the demonstrative pronoun. In GB bao is a WH-word. The subject NP of the embedded sentence has been dropped as does happen in pro-drop languages. The antecedent is not the subject of a relative clause, but an implied object of the relative clause because there is no subjectival concordial agreement between it and the predicate of the relative clause. This simply means that the subject of the relative predicate is not identical to the antecedent.

(c) Adverbial

According to Doke and Mofokeng (1967:425-426), there are various types of adverbial relationship into which the subordinate relative predicate may be brought. This kind of relative construction is formed by a relative predicate which will then be followed by the respective adverb formed by inflecting the absolute pronoun representing the antecedent as in examples in 23 below.

- 23 a. ntlo (eo ke dulang ho yona) = Locative relationship
b. lekgowa (leo buang le lona) = Conjunctive relationship
c. dikobo (tseo a robalang ka tsona) = Instrumental relationship
d. noha eo setsomi se lonngweng ke yona) = Agentive relationship
e. lehlanya (leo ngwana a tsamayang iwalo ka lona) = Manner comparison relationship
f. Masimo (ao re kgang metsi pela ona) = Positional relationship

(d) Copulative relationship

This type of relative construction affects only the copulatives formed from substantives. In this case we observe that the antecedent is the subject of the relative clause formed by a copulative. Due to the fact that the concord employed before the copulative verb consisting of a relative suffix -ng, is an indefinite concord not in agreement with the antecedent, the relative construction of indirect relationship is usually employed as in 24 below:

- 24 a. Bana bao e leng ditlokotsebe
b. Thabo eo e leng morui

Vitale examined Swahili data in his analysis of relative clauses. According to Vitale there are three types of relative clauses in Swahili, namely full relative, reduced relative and tenseless reduced relatives.

Full relatives contain the comp amba-. These are viewed by Vitale as basic. Vitale posits a new morphological rule of Comp Affix Attachment, which according to him is of a vital importance in this type of a relative.

According to Vitale reduced relatives entail an affix hopping rule whereby the Comp affix hops to a particular morphological slot within the verb, the Comp amba- is then obligatorily deleted. The Adjacent NP Constraint in which two NPs cannot occur adjacent to one another is seen as applicable to reduced relatives only.

Tenseless reduced relatives were regarded to function both semantically and syntactically like adjectives and the comp affix was moved to the end of the verb with obligatory deletion of the tense marker (Vitale 1967:131-132).

Traditional grammarians were able to detect the orders and forms of morphemes in Sotho relative clauses for instance in indirect relative construction of objectival relationship the order is as follows:

A + D + (S) + SC + OC + V - RS

and the relative pronoun is usually at the head of its clause. We observe that Doke and Mofokeng have unfortunately devoted very little time on syntactic description.

Coming closer to (Vitale 1967) studies in Swahili relative construction, we observe that the surface structure is arrived at through more than one transformational rule. In sentence (16) *ka* is a locative according to the traditional grammarians but the very same *ka* is not regarded as a locative in GB but it is a specifier. According to Doke and Mofokeng (1967:425) when a substantive in the locative is the antecedent, the demonstrative pronoun used is that of Bantu class 18 *moo*. The adverb *teng* usually follows at the end of the relative clause as in 25 below.

25. Thabeng moo a ahileng teng
 mountain+LOC where he lives
 on the mountain where he lives

Sometimes a similar construction is used without an antecedent, resulting in a pronominal relative clause of the locative type which is used adverbially as in 26 and 27 below.

26. Ke tseba (moo a dulang teng)
 I know where he lives
27. Ka ntle ka moo ba dutseng teng
 locative NP C Dem AGR V+ng
 Outside where they stay

4.3 INDIRECT RELATIVE CLAUSES

In 4.3 we give a GB analysis of the indirect relative clauses.

The indirect relative clauses differ from the direct relatives in the sense that the subject of the relative predicate is not identical to the antecedent as in 28 below.

function of the relative clause is to modify the noun.

The clause bao ke ba boneng in batho bao ke ba boneng ba shwele, is a relative clause of indirect relationship because the antecedent batho represents the object. This antecedent is always represented by a demonstrative pronoun (generally in the form eo, bao, seo, tseo, etc.).

At the beginning of a relative clause, relative pronoun can be noticed. According to Culicover (1982:222), relative pronouns are the elements that appear at the beginning of an indirect relative clause and they therefore introduce the relative clause.

In example 28 batho bao ke ba boneng bao is the relative pronoun and thus introduces the relative clause.

*29 batho bao ke ba boneng batho ba shwele

*30 batho ke ba boneng bao ba shwele .

Sentence 29 is syntactically unacceptable. This is so because the verb boneng normally occurs with a Noun Phrase but once there is a an object clitic incorporated in it the argument position is supposed to be occupied by a trace. The incorporated clitic is coreferential with the antecedent batho. Sentence 30 is ruled out because the relative pronoun which must appear at the initial position of a relative clause is at the end of a clause. The relative pronoun bao in 30 is a WH-word and therefore should move to Comp by Move alpha. If it is assumed to be immediately after the relative verb boneng, it would still be ungrammatical because the incorporated clitic ba should have left a trace

instead ba. There is a view which a doctoral research could explore, namely that the ba is in fact base-generated. In other words, ba does not move from the object position to Comp. It is in Comp in the D-structure. This view, however valid, would need more time and space to be pursued in such a limited research. There are therefore two levels which precede each other in strict order, namely a morpho-syntactic operation and syntactic operation. The morpho-syntactic operation moves the clitic into the verb prior to lexical insertion and the verb retains its subcategorisation frame. Hence, the projection principle would require that the position after *ba boneng* should be occupied. It is this position which ba occupies.

Sentence 31 below, however, presents another problem with our analysis. The position immediately after the relative pronoun (WH-word) is occupied by setjhaba. In 28 the position is empty. It is occupied by an empty category called small *pro*.

31. Morena eo setjhaba se mo hloileng o fihlile
 NP SV-AGR NP AGR VP AGR VP

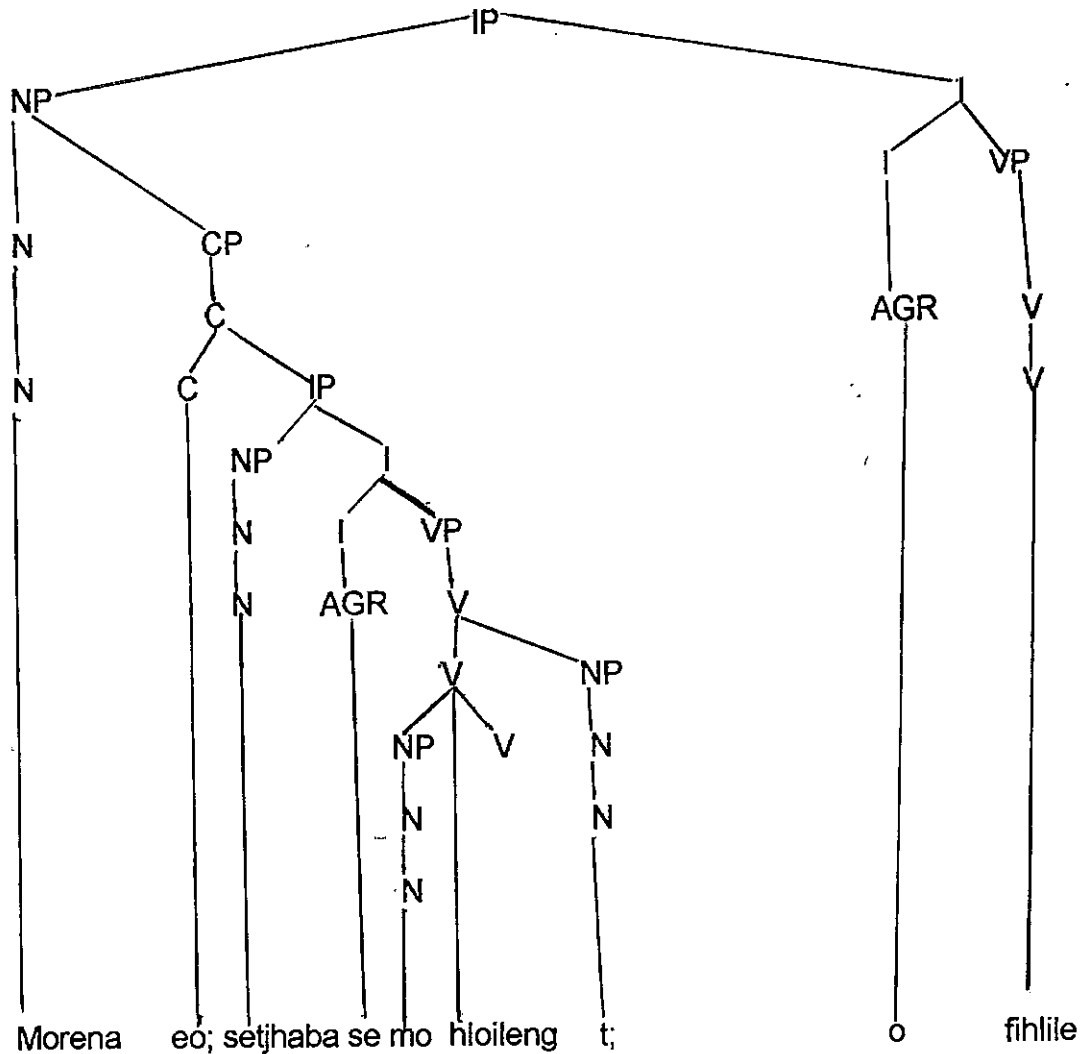

The subject of the relative predicate is setjhaba (nation) and the antecedent morena is coreferential with the object of the relative predicate and the subject of the matrix verb. Secondly, what traditional grammarians call the relative concord is the subject verb agreement of the relative clause in generative grammar. The enclitic -ng is suffixed to the relative verb as is the case in the direct relatives.

As in the direct relative clauses, movement is involved in the indirect clauses. Move-

alpha move items from argument positions to A-bar positions. This movement is constrained by the projection principle as can be demonstrated by the fact that the position vacated by the WH-word is occupied by a trace in 31. In addition, the moved WH-word does not occupy any theta position since Comp is a non-theta position. Other principles also contribute in constraining this movement. Subjacency, for instance, requires that the first empty Comp position should be the landing site for the moved WH-word. In 31 eo (who) in the Deep structure has moved from the argument position which is in this case (object of mo hloileng) to the Comp in the surface structure and by so doing a trace is created. The trace is co-indexed with eo (who) in the Comp.

According to Empty Category Principle, we expect that the trace should be properly governed. Hence, the empty category is properly governed by the relative verb hloileng (hate) since hloileng is a lexical item. The enclitic -ng is seen when the tense marker nè is involved in the construction of a relative of indirect relationship like in 32 below:

32. lesaka leo batho ba neng ba le ahile

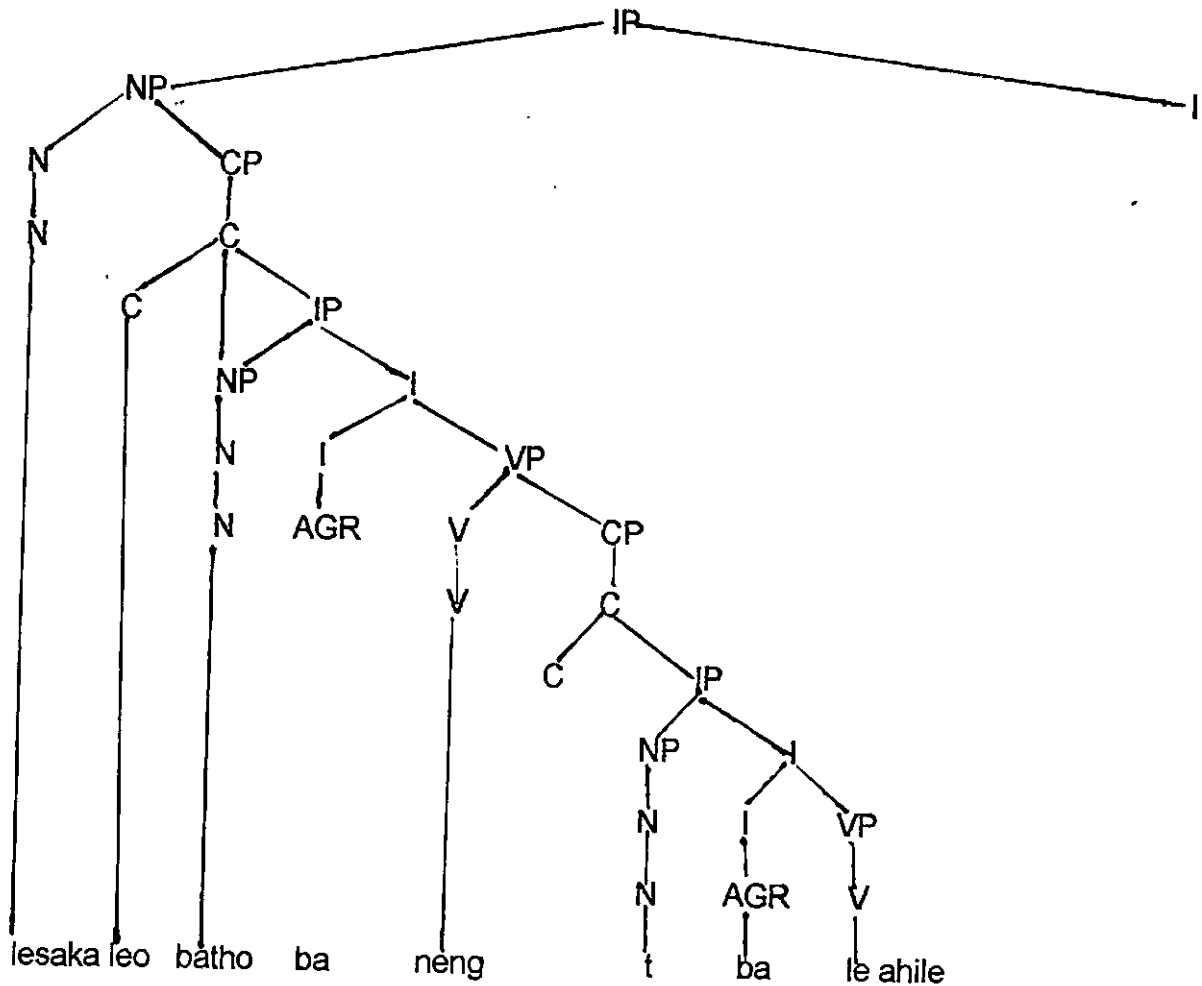

The tense marker nè has the implication that the action has taken place long ago.

Note here that the enclitic -ng is attracted by the tense marker which becomes neng.

The continuous tense marker is constructed by the following morphemes: sa ntse, sa ntsane sa, and ntse as in 33 below:

- 33.
- a) Mose oo ke sa ntseng ke o aparā
 - b) Mose oo ke sa ntsaneng ke o aparā
 - c) Mose oo ke sang o aparā*

d) Mose oo ke sa o aparang

e) Mose oo ke ntseng ke o apara

Mose oo pro ke sa ntseng pro

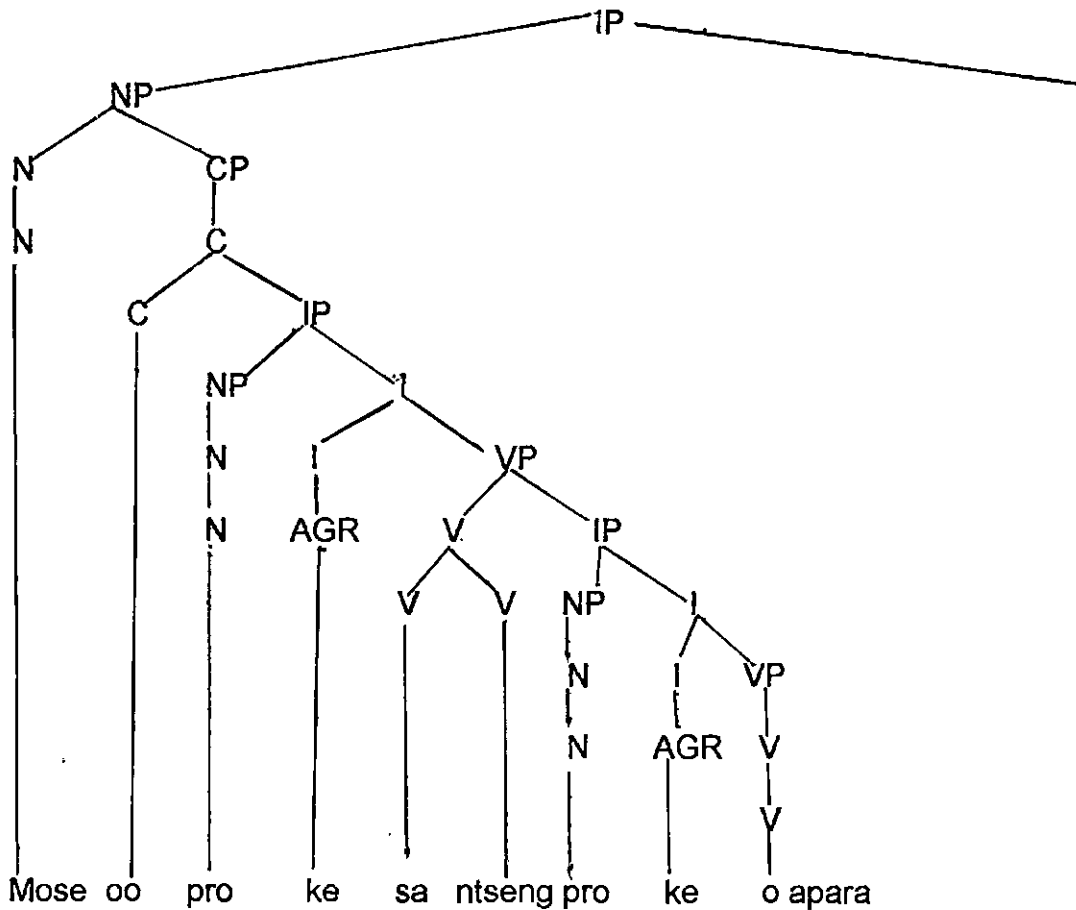

The enclitic -ng is licensed in sentences 33a, 33b, 33c and 33e. Here it is implied that the action is still continuing that is, it is not yet completed.

The problem is in sentences (c) and (d). Sentence (c) is not acceptable in Sesotho because it is both semantically and syntactically deviant wrong. Sentence (d) on the other side is ambiguous. Firstly, it has the implication that a person did not put a dress

on; that is, the morpheme sa in this instance has the negative meaning and thus serves as a negative marker. Secondly, except for the negative implication, this sa functions as a continuous tense marker but what is surprising about this sa is how it totally differs from its counterparts. Its counterparts are marked by a relativiser -ng.

This continuous tense morpheme differs from other morphemes in the sense that the other three continuous tense markers do display some common characteristics during the indirect relative constructions where the AGR is repeated in the sense that the first AGR occupies the position before the continuous tense marker and the second AGR follows immediately after the tense marker in (34) below:

- 34 a. Mose oo ke sa ntseng ke o aparā
b. Mose oo ke ntseng ke o aparā
c. Mose oo ke sa ntsaneng ke o aparā

The order is not so in the case of sa in 35 below:

35. *Mose oo ke sa o aparā

If we attempt to copy sentences in 36 the sentence will be bad and unacceptable in Sesotho as in the following sentence.

36. *Mose oo ke sa ke o aparā

We notice that the enclitic -ng is attracted by sa ntseng, sa ntsaneng and ntseng. But the very same enclitic -ng is not licensed in the case of tense marker sa as in sentence

in 37 below.

37. *Mose oo ke sang o apara

This sentence is bad in Sesotho. From this discussion I can conclude that the continuous tense marker sa is not licensed in the construction of a relative of indirect relationship. This is also seen when the deficient verb stem ye is involved in the relative construction as in 39 below.

39. Setulo seo ba yeng ba se dule

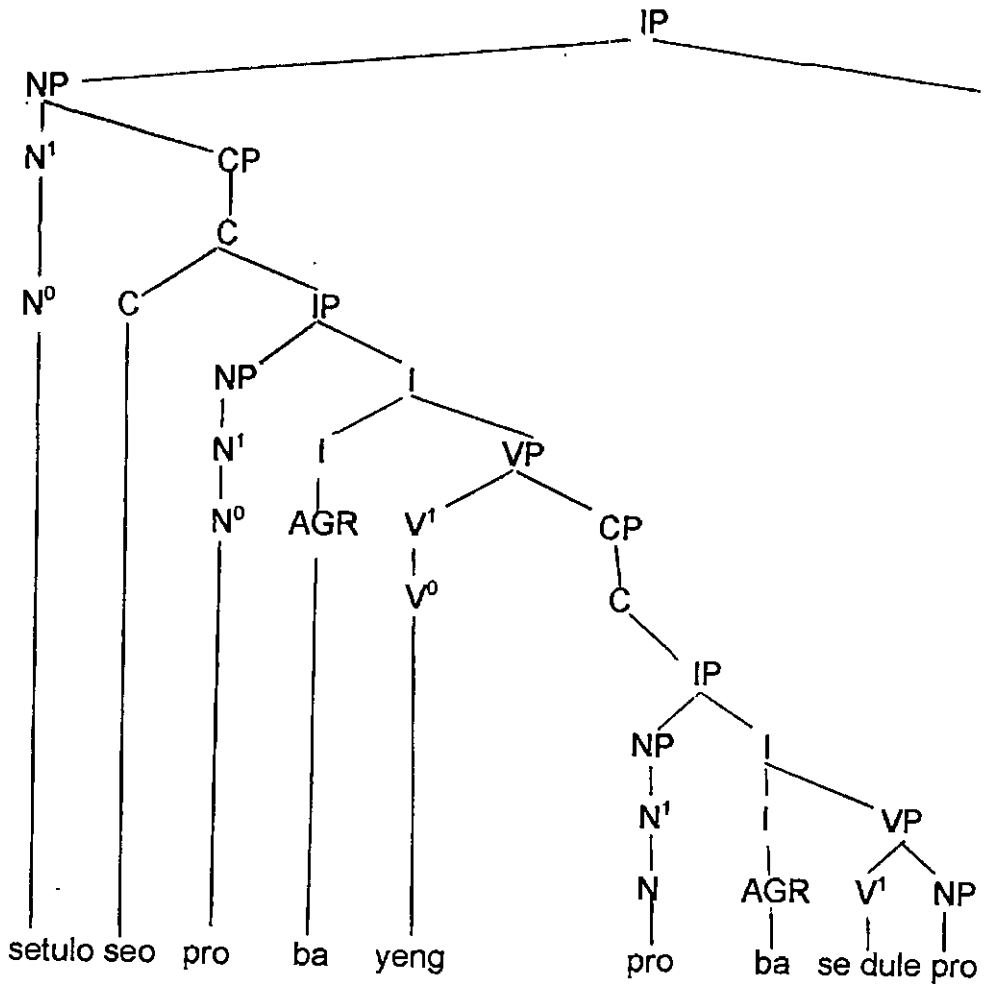

The deficient verb stem ye has the implication that the action is a habit. In the ordinary participial construction like in: batho ba ye ba se dule there is no attachment of the suffixal -ng on a deficient verb stem ye but when ye is involved in a relative construction, the suffixal -ng as in (40) below:

40. Batho bao re kileng ra ba bona

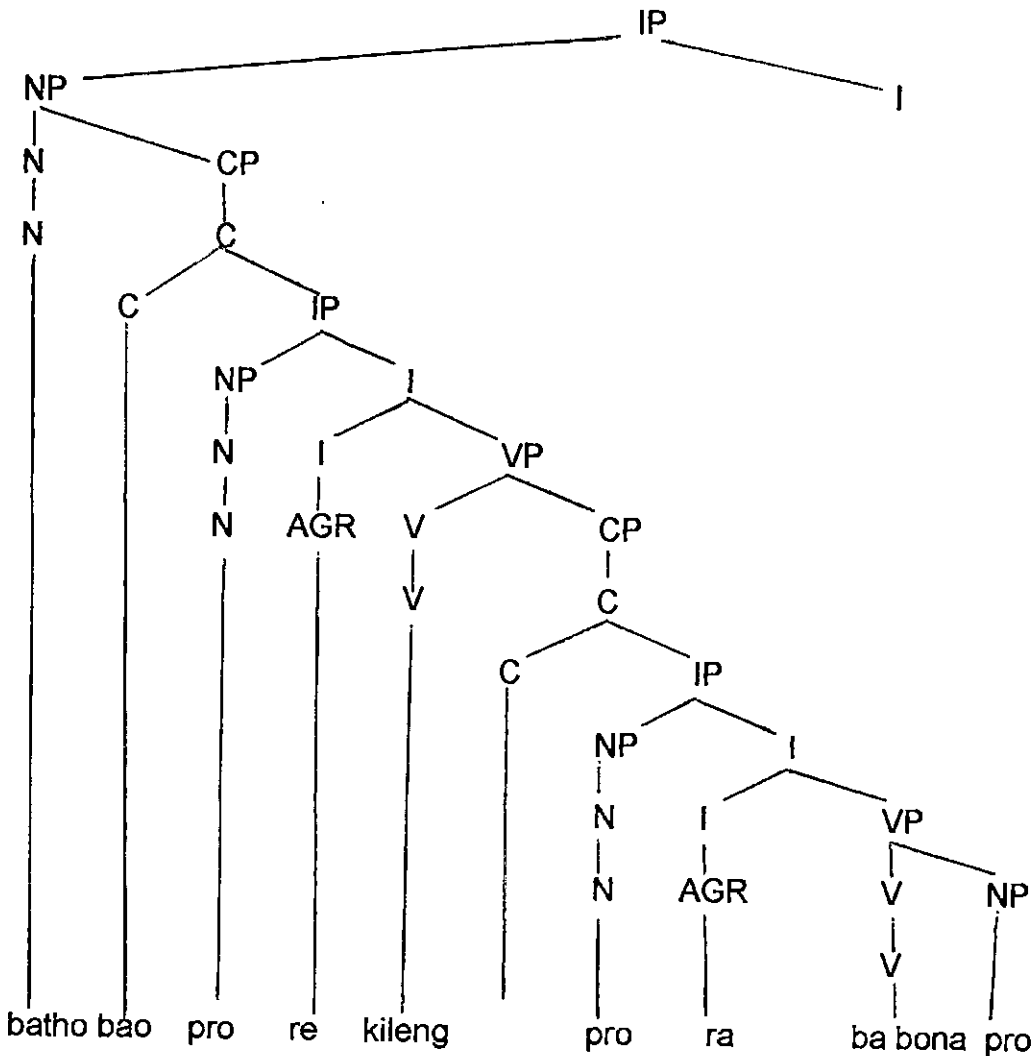

The deficient verb kile indicates that the action has taken place long ago and that the action is not a habit but it occurs once after a long time. We observe that when the deficient verb stem kile is used in the ordinary participial construction, there is no attachment of the suffixal -ng to it as in (re kile ra bona batho). In the case of a relative clause, the suffixal -ng which could have been attached to the complement verb is attached to the deficient verb stem kile.

This habit of a deficient verb stem assuming the relative suffix -ng in a relative construction is also observed in a deficient verb stem hlola. Like other deficient verb stems dealt with, hlola also assume the relative suffix -ng in a relative construction as in sentence 41 below:

41 Lehlanya leo re hlolang re le tsheha

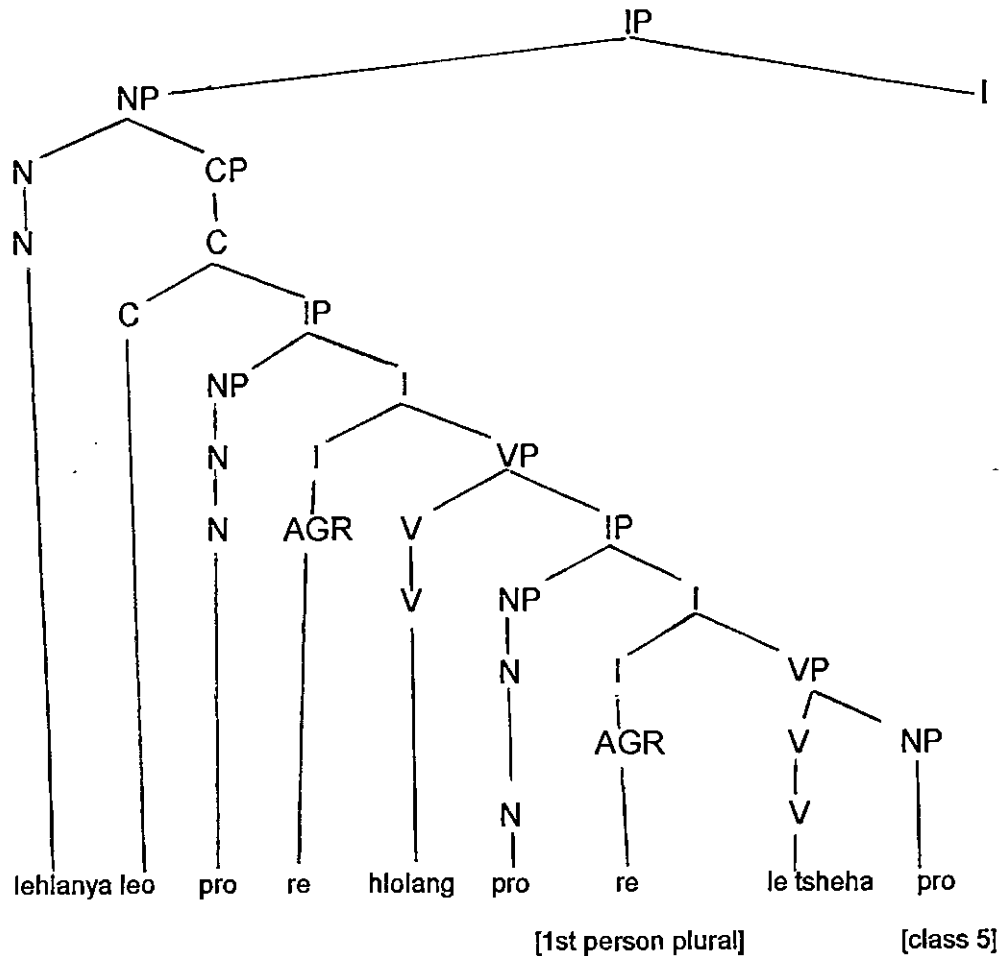

42 Sekolo seo re ka se etelang

In the above sentence, there is a deficient verb stem in a relative construction. This deficient verb stem is ka. In this construction, ka has the implication that there is that possibility for an action to happen.

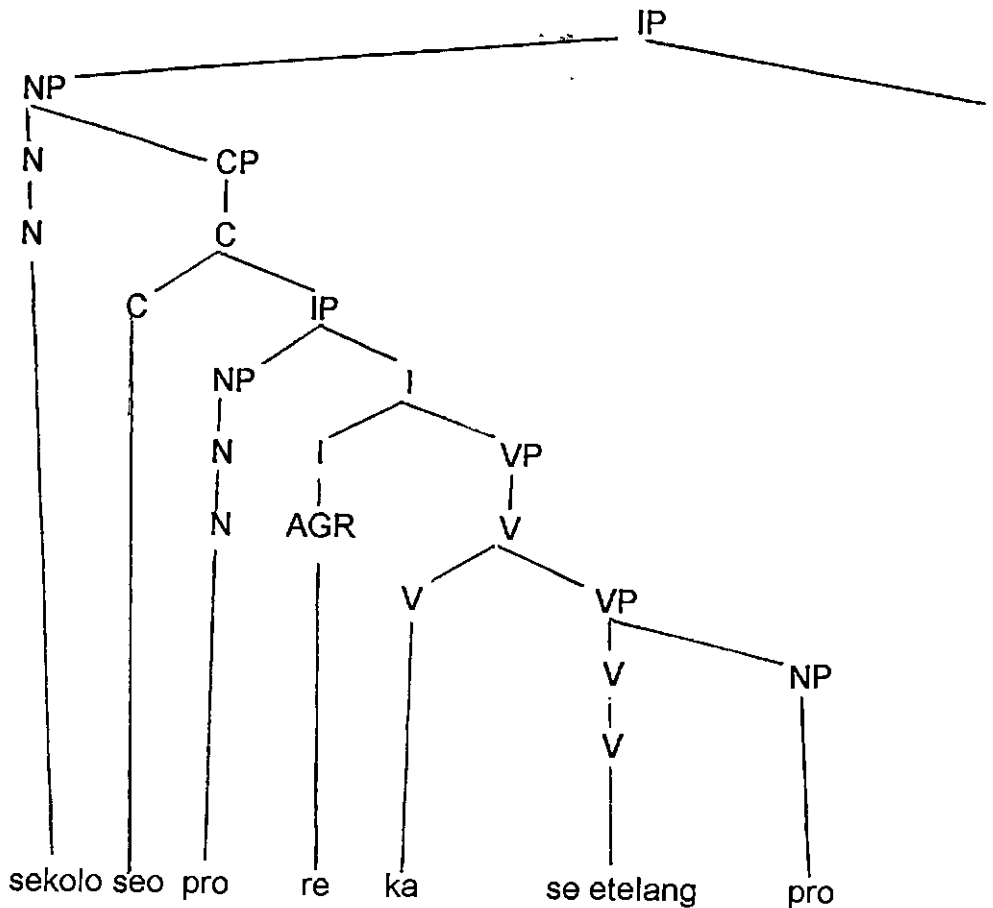

The deficient verb stem ka behaves totally different from other deficient verb stems.

The other deficient verb stems which we dealt with before showed a common feature when the relative suffix -ng is attached to them.

But ka does not assume the relative suffix -ng. When ka appears, the relative suffix -ng is attracted by the complement verb. We have already discussed that when ka occurs in a relative construction and ka is in a negative form, then ka seems to assume the relative suffix -ng as in sentence 43 below:

43 Lerako leo ba ke keng ba le aha

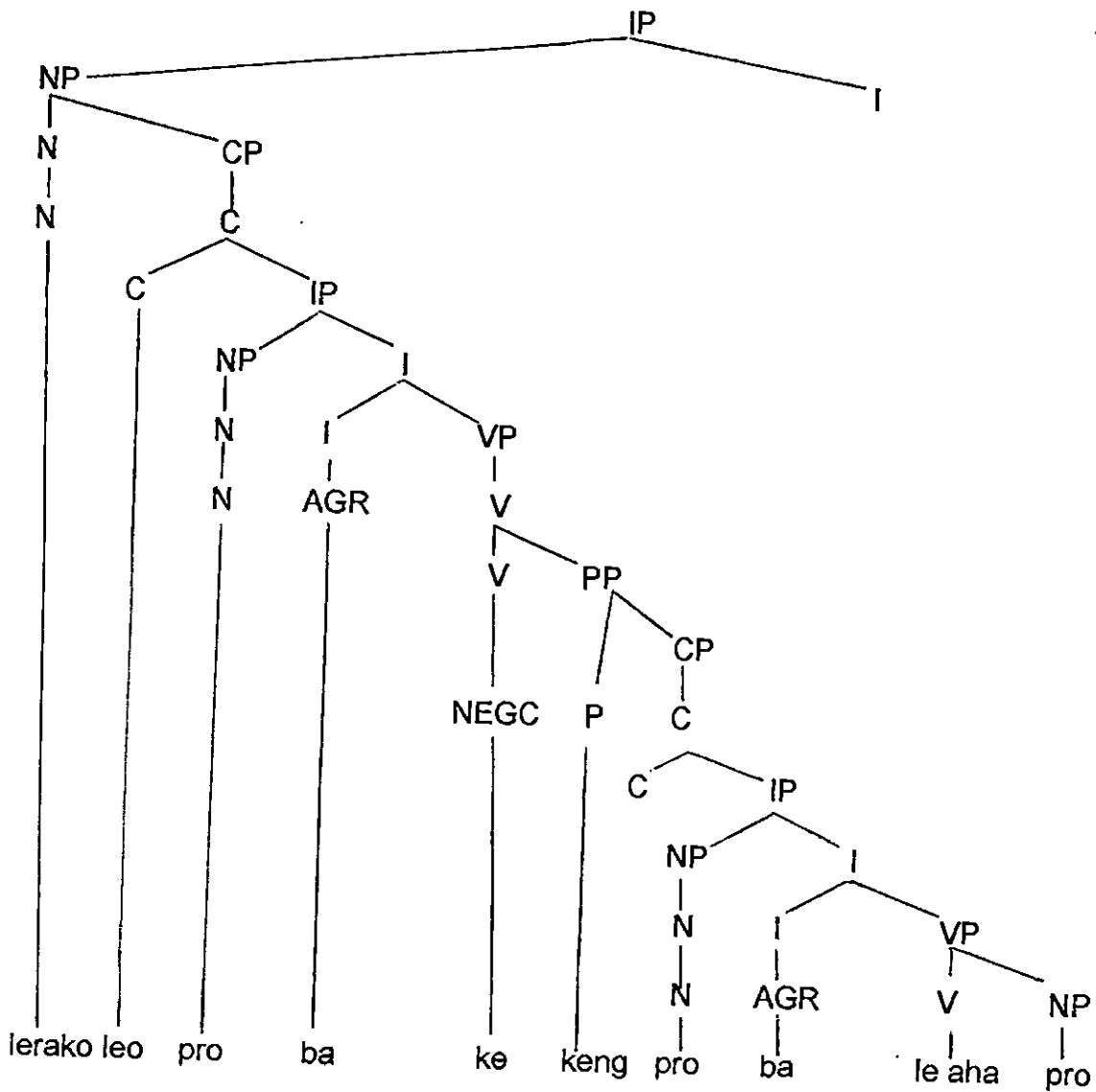

From this discussion, I can conclude that when ka occurs in a relative construction and is in affirmative form the deficient verb stem does not assume the relative suffix -ng. The eclitic -ng is seen when the tense marker ne is involved in the construction of a relative of indirect relationship like in 44 below:

Lesaka leo batho ba neng ba le ahile

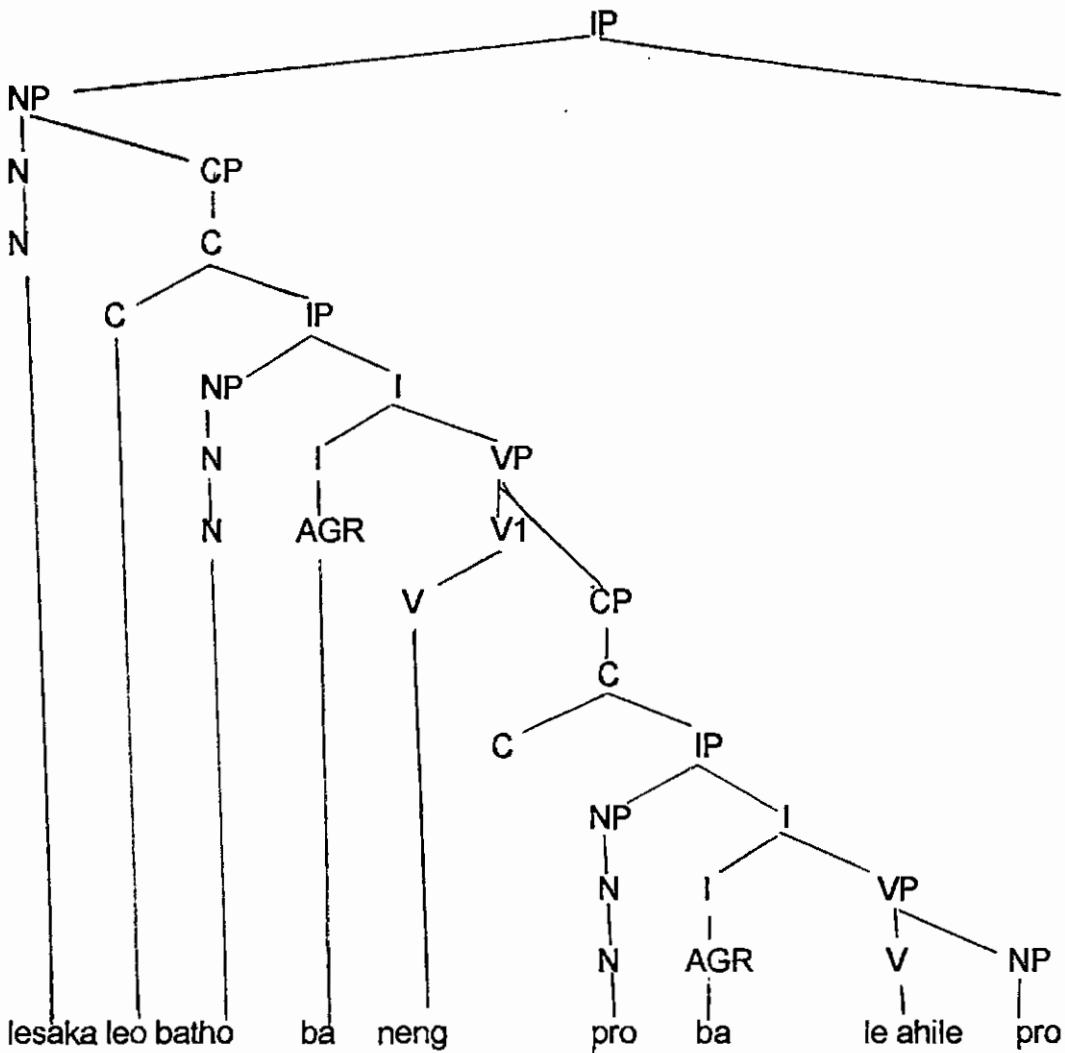

4.4 CONCLUSION

We realize that the relative clauses of direct relationship behave like those of indirect relationship in the sense that the enclitic suffix ng is also attracted by the tense markers.

We have observed that not all of the continuous tense markers can be licensed in the construction of relative clauses.

CHAPTER 5

5.1 INTRODUCTION

This chapter will show that a resumptive pronoun substitutes for a trace. Furthermore, a clear proof will be given that a resumptive pronoun is indeed pronominal. Finally, a difference between an adverbial and a prepositional phrase in Sesotho will be examined.

5.2 ANALYSIS

In 45 below, after move alpha has applied no trace is left behind since the empty category is occupied by the resumptive pronoun.

45 Mosadi eo ngwana wa hae a kulang o tsamaile
 (A Woman whose child is ill has left)

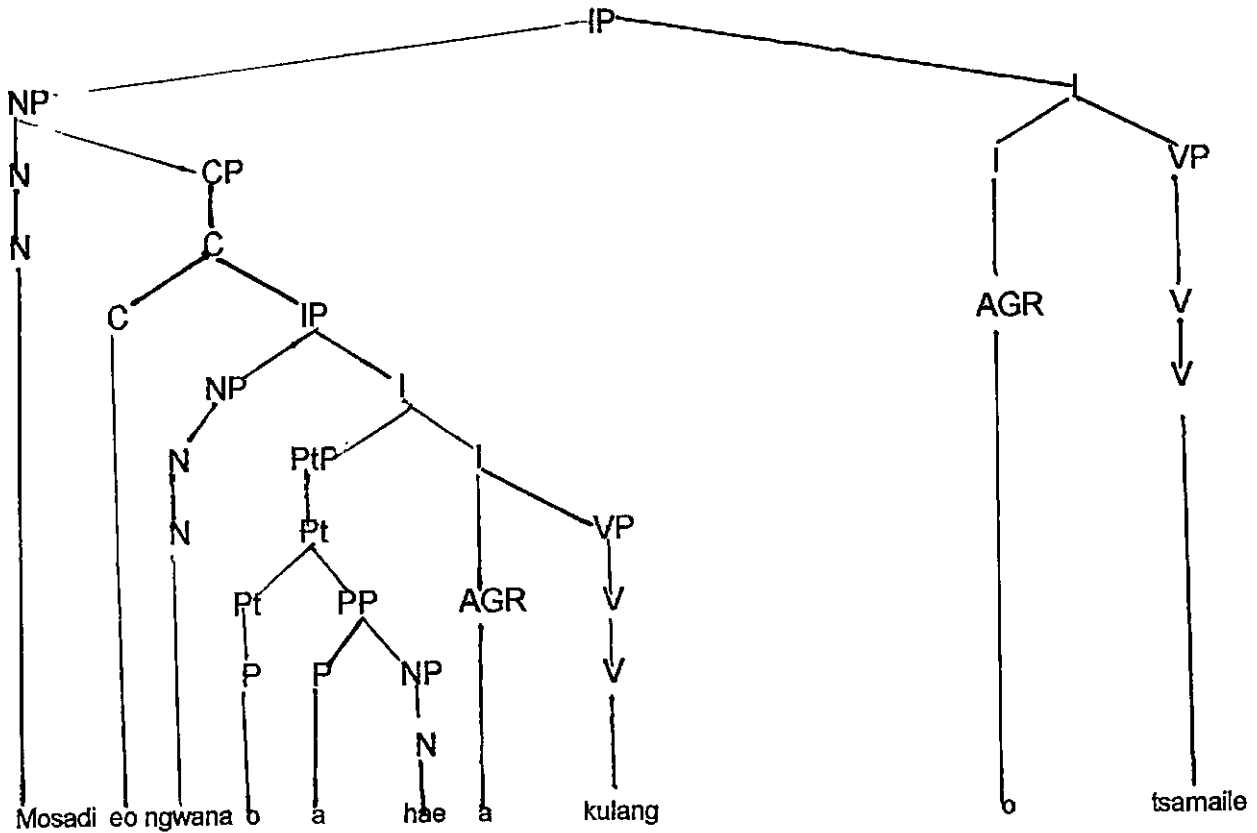

In 45 above hae is properly governed by a preposition a (of) since a is a preposition (P). Hae (hers) receives its case from the preposition a. We also realize that there is no violation of the theta-criterion since the space occupied by hae is an argument position left by the WH word eo (who) in the Comp. In other words, the resumptive pronoun substitutes for the trace. This means that all properties that would characterise the trace become properties of the resumptive pronoun.

Sesotho is one of those languages where a resumptive pronoun substitutes for the trace. In Sesotho, prepositions cannot be left stranded. Since the trace does not have phonetic content, it cannot be the complement of the preposition.. Sentence 46 below illustrates clearly what traditional grammarians call the indirect possessor of the subject of the relative verb (Cole 1955). The phrase marker in 46 below represents an analysis for these sentences which is consistent with GB principles. In 46 below, relativization is on the possessor of the object of the relative verb.

46 Monna eo ke shebileng mosadi wa hae o shwele

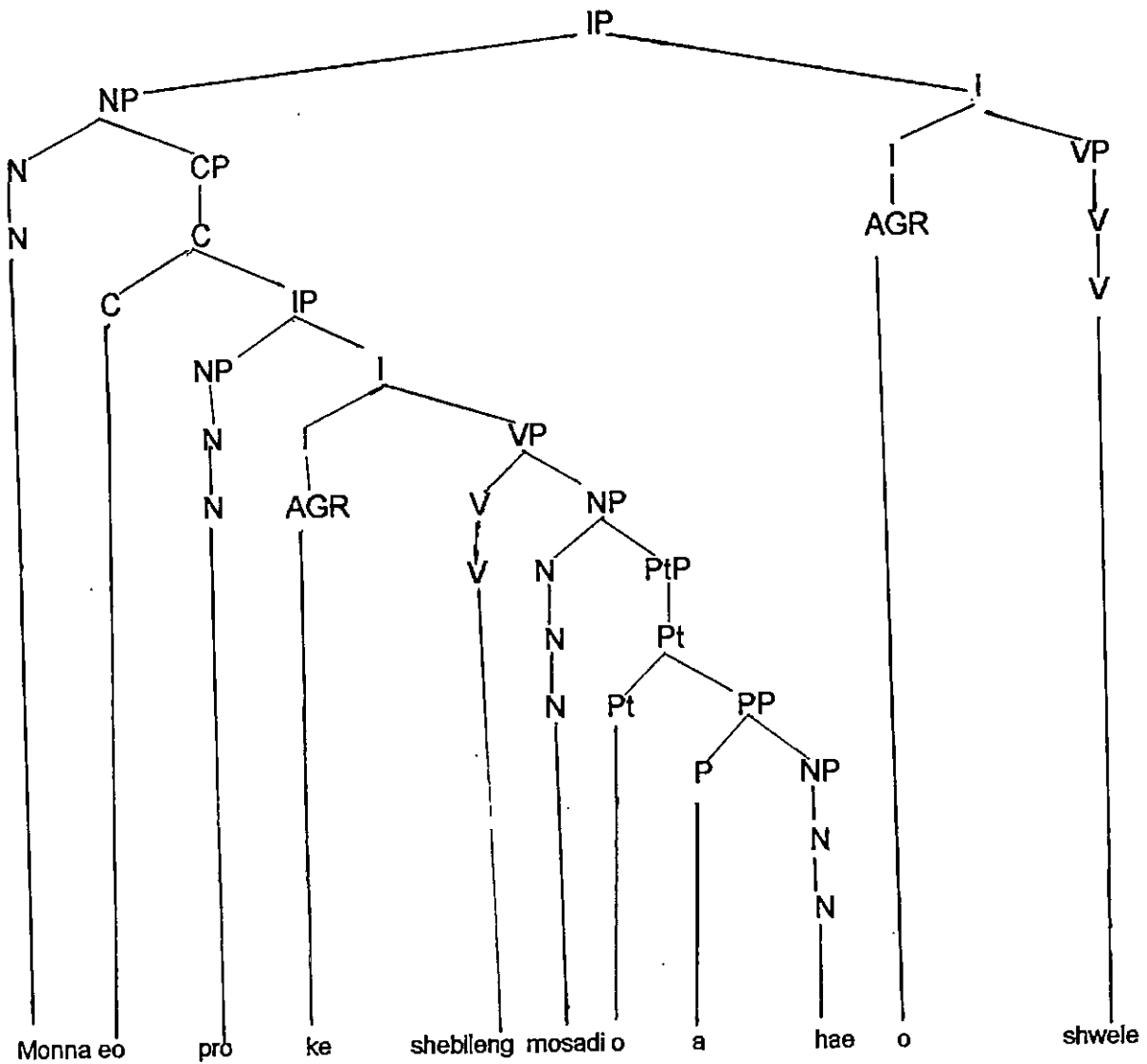

In 46 above the object NP mosadi denotes the possession of the antecedent monna. The complement to the preposition a is the WH-word eo in the D-structure. The WH-word eo moves to Comp by Move alpha. Once moved, the preposition is stranded and therefore the empty category receives phonetic content in the form of a resumptive

pronoun. This resumptive pronoun carries the same index as the antecedent NP monna. There is, therefore, a binding relation between monna and hae. This is so because monna C-commands hae. The governor of hae is the preposition a dominated by PP. The P and hae are contained in the same NP. This NP is, therefore, the governing category (GC) for hae. Hae is therefore free in its governing category because monna is outside this governing category. This predictably confirms that the resumptive pronoun is indeed pronominal. Its position satisfies principle B of Binding theory.

The view that hae is a resumptive pronoun that has replaced a moved WH-word is indeed controversial. The controversy is a consequence of the fact that in GB there is only one transformational rule, namely Move Alpha. When one entertains some substitution rule, it would imply that such substitution is not a syntactic rule. Some other level should be invoked to justify the substitution. For our purposes in this limited research it would not be appropriate to argue for this view or against this view. What is crucial to us is the fact that the literature on resumptive pronouns as well as on movement rule provides the necessary basis for us to analyse Sesotho relative clauses.

Furthermore, we realize that the subject position occupied by mosadi in 46 above is occupied by small pro. The presence of small pro in Sesotho is brought about by the fact that the Extended Projection Principle requires all clauses to have a subject. Since Sesotho is a pro-drop language, one could expect that small pro would occupy subject position quite frequently. Another example where an empty category could be observed is in 47 below. This other empty category is the big PRO.

47 Motho eo ba batlang ho mmolaya

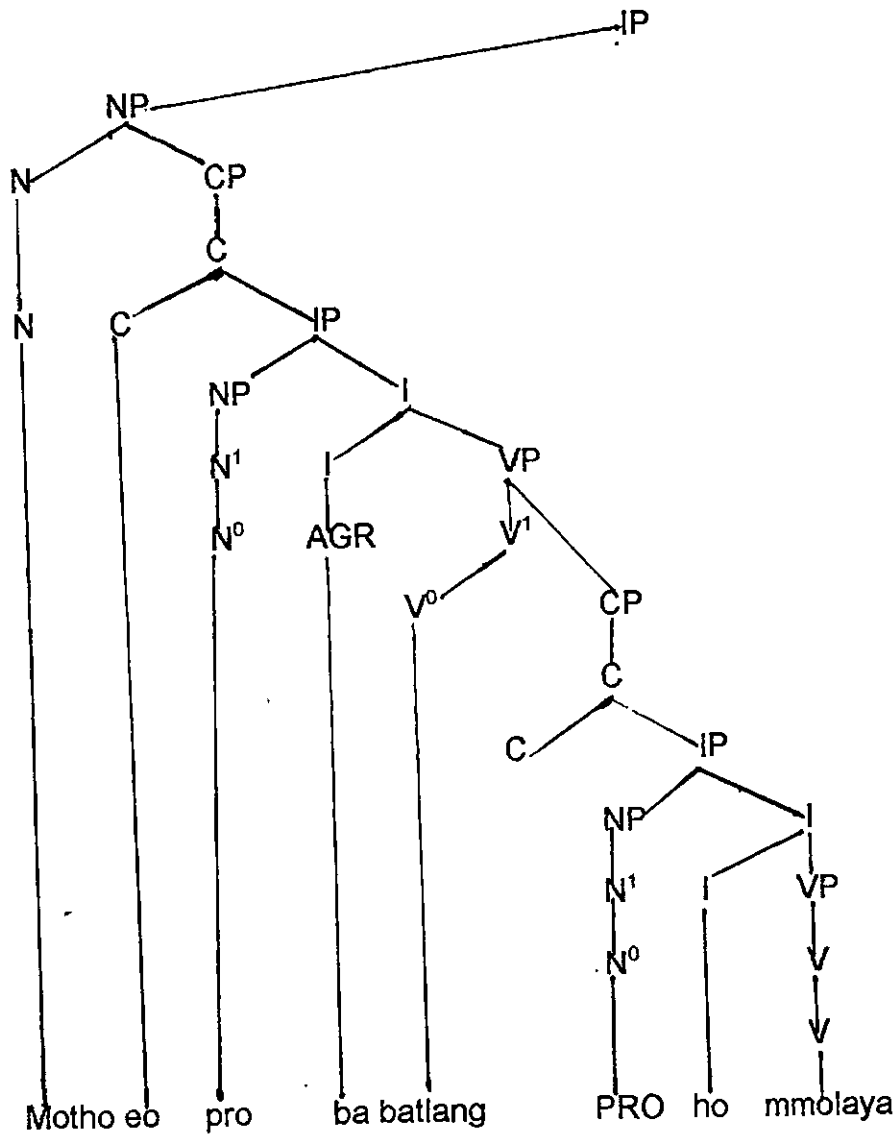

Motho o hopola a tlohela diphuputso
 NP AGR VP AGR VP NP

He remembers discarding the investigations

relative clause = Motho ya hopolang a tlohela diphuputso

In 47 the embedded innermost IP has big PRO as the subject because of the infinitive ho. In other words, in the sentence ho mmolaya there is no AGR (agreement). The

ho is just an infinitive. The sentence is therefore tenseless. Hence it is only big PRO that can occupy the subject position of the clause. The reason is that big PRO is both anaphoric and pronominal. Small pro is pronominal and non-anaphoric. Small pro receives case from the tensed inflection. Big PRO does not receive any case. Since INFL is the one which dominates a non-agreement, non-tense morpheme known as INF< inflection is therefore a non-governor. This simply means that a big PRO is not governed. This tallies very well with what we expect. Big PRO must be ungoverned.

Following Chomsky (1981) and Sells (1985) big PRO is indeed as a pronominal anaphor. According to the Binding Theory, anything which is pronominal is free in its Governing Category while on the other hand an anaphor is bound in its Governing Category. From this definition of a big PRO we can deduce that a big PRO has contradictory characteristics. It is impossible for a single entity to be both free and bound simultaneously. To bring about a balance in this paradoxical situation and for a big PRO to exist, it should therefore remain ungoverned. It is the maximal phrasal category CP that guarantees that big PRO remains ungoverned since CP is a barrier to government.

In the relative of indirect relationship where an affirmative future tense lla is involved, the verb does not seem to attract the enclitic -ng. Example 47 below provides fairly direct evidence for this assumption:

47 Ngwana eo re tla tsamaya le yena.

Child WH-word pro AGR will go P him

The child with whom we will go

In 47 the verb tla does not seem to attract the relativiser -ng. If it were to attract the -ng, the sentence would be as the ill-formed sentence 48 below:

48 * Ngwana eo re tlang tsamaya le yena.

However, some speakers render 48 grammatical by inserting the infinitive ho immediately after the tlang as in 49 below:

49 Ngwana eo re tlang ho tsamaya le yena.

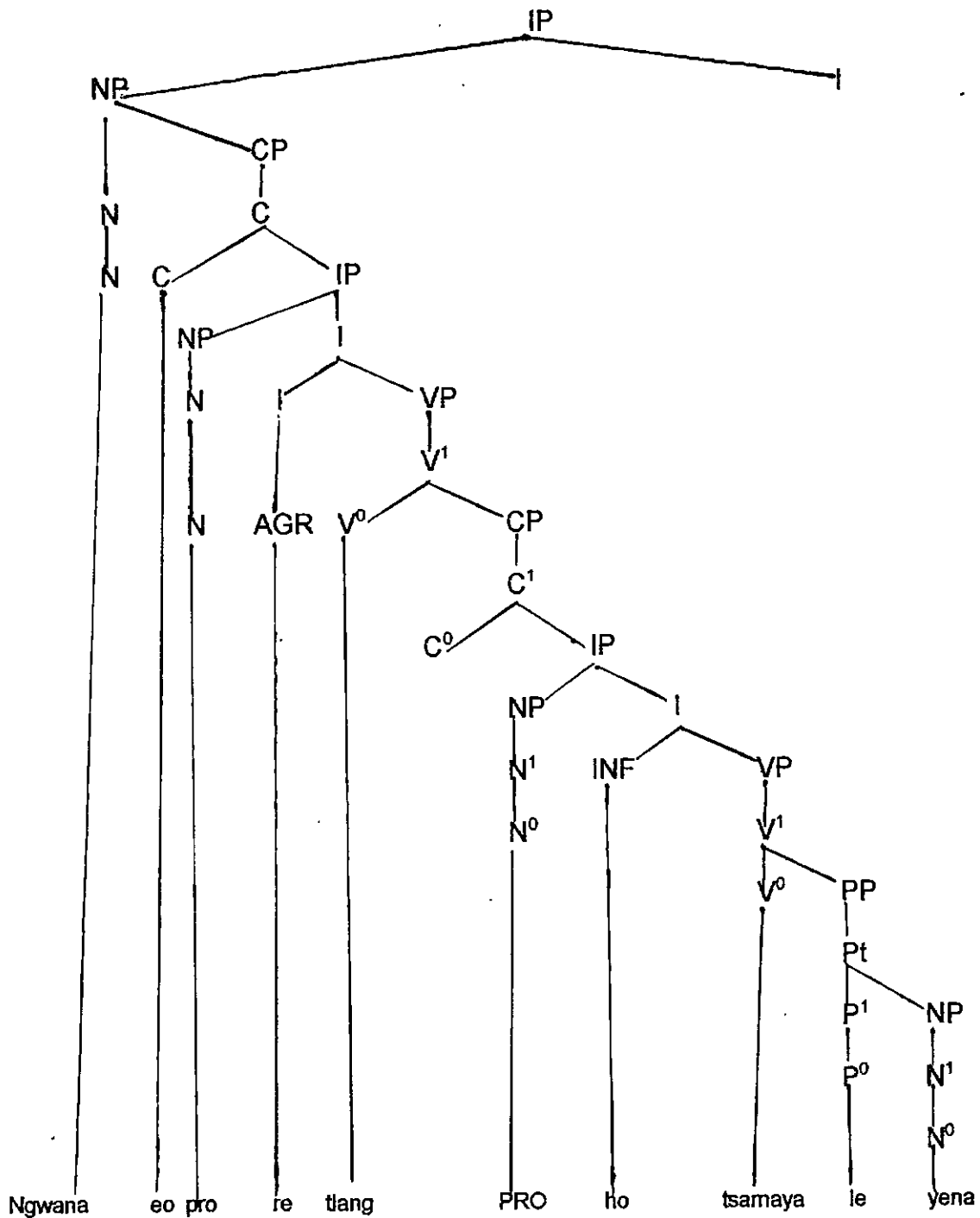

In other words, the verb tlang in 49 above simply subcategorises for a CP. The subject of the IP embedded is the big PRO. In terms of diagnostics for categories, the phrase le

yena is regarded as a prepositional phrase but traditional grammarians refer to it as an adverbial conjunctive relative. In (50) below the phrase ka tsona is also a PP:

(50) Dieta tseo ntate a binatang ka tsona di fedile

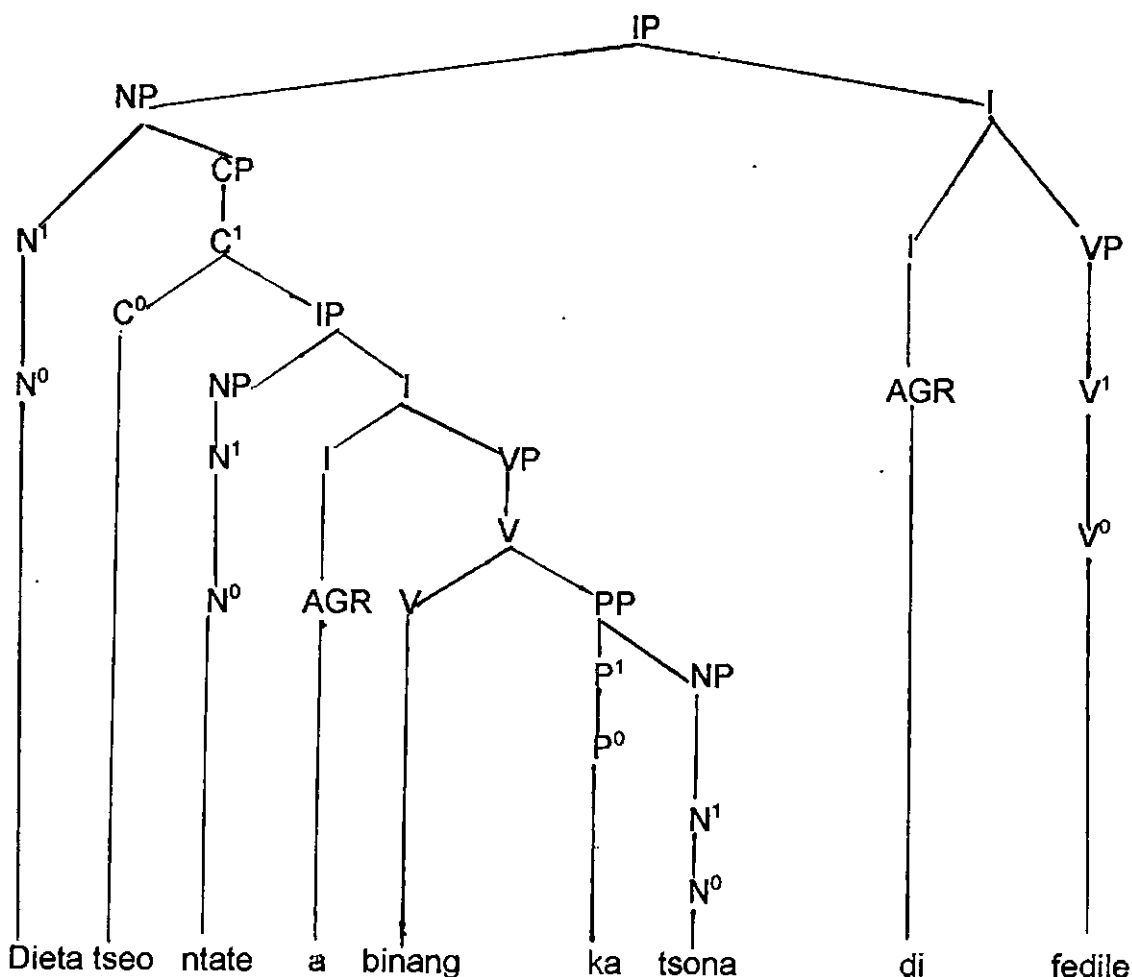

In (50) the moved tseo in Comp carries the same index as the resumptive pronoun tsona at S-structure. There is therefore a binding relationship between the two. The antecedent is the instrument. Hence, traditional grammarians called such a sentence a relative clause of indirect instrumental relationship. The problem of the resumptive

pronoun can be solved by just assuming that it is a language specific stylistic device to substitute traces after prepositions at either PF or LF level.

In GB both a Prepositional phrase and an Adverbial phrase can be modifiers of verbal heads. Adverbial heads, however, do not theta-mark or case mark anything.

Prepositions, on the other hand, theta-mark and case-mark NP complements as in sentences 49 and 50 where the le and ka as prepositions theta-mark, case assign and govern the NP complements, yena and tsona respectively. It is clear that the above structures would not reveal this in the traditional grammar.

Modifiers can move around as in 51 below:

51

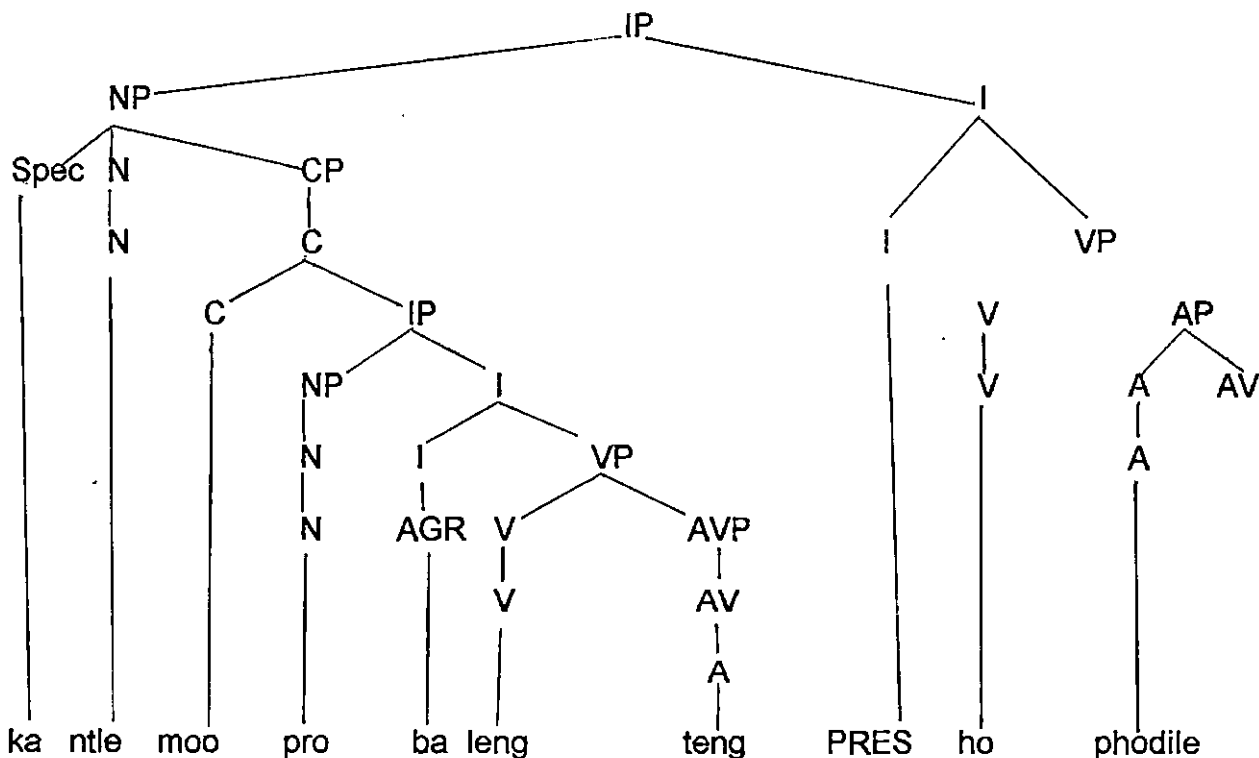

The ka preceding in 51 is a locative according to traditional grammarians. In GB, however, this ka is a specifier. The moo is the WH word formed from an adjunct position. If one assumes that the WH-word is in fact from an adjunct position to Comp, then the trace would have no governor. Haegeman argues that such traces are antecedent governed, rather than lexically governed (Haegeman 1991).

In the case of a relative construction of places where moo is involved, the verb will take the ending -ng. Teng is sometimes put at the end of the clause (moo..... teng)

Embedding of a clause is done after a VP and thus the embedded clauses is qualifying a verb and not a noun phrase as in 52 below:

52 Mme o rata moo moroho o lengwang teng.

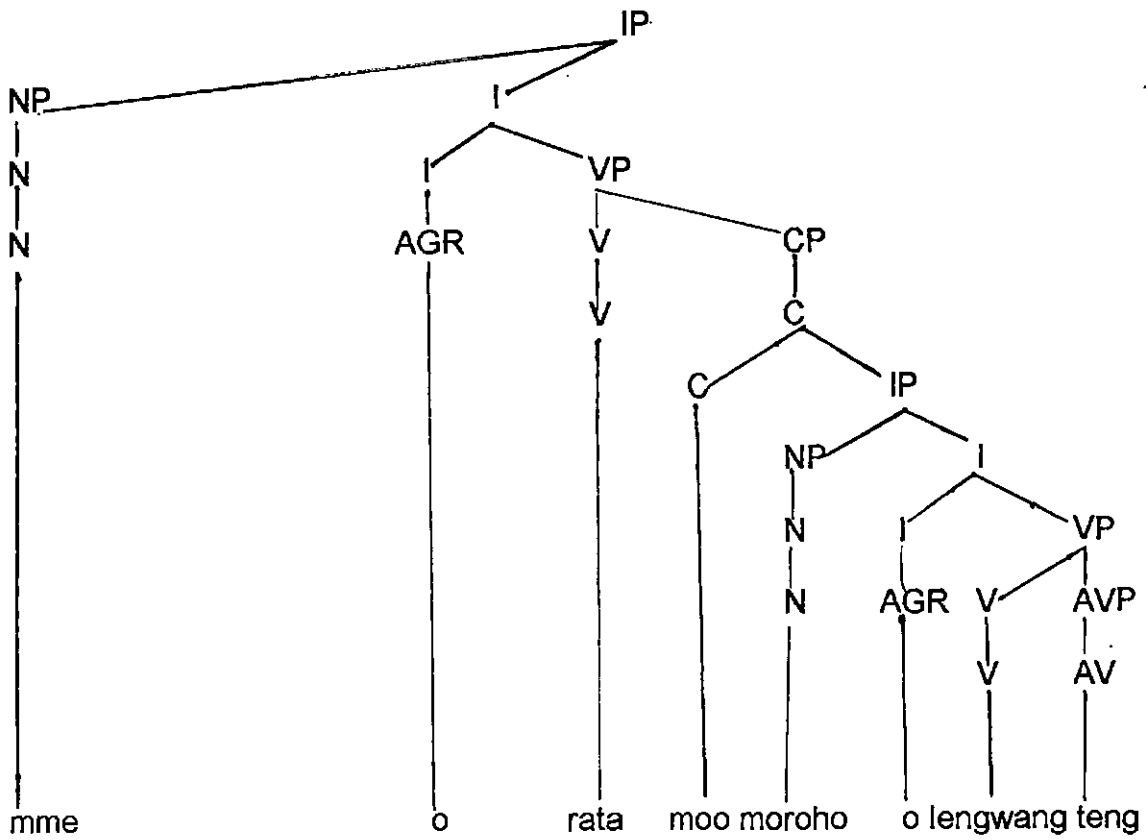

But it is not in all cases that teng is put at the end of the clause, teng can sometimes be omitted like in 53 below:

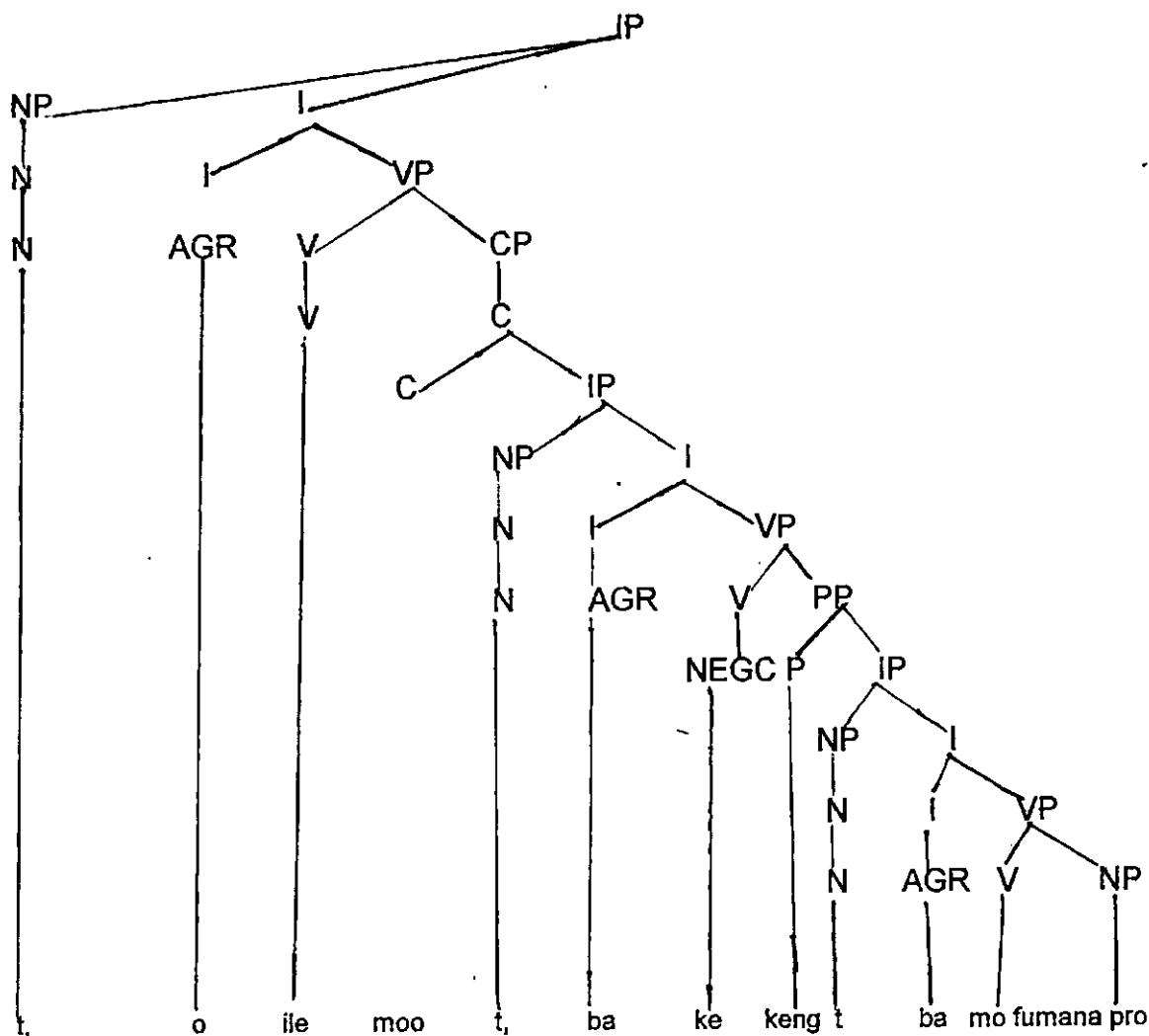

We notice that in the case where teng is involved and occupies the position at the end of the clause in the relative clause of place, the verb does not take the ending -ng in the affirmative future tens like in 54 below.

54 Baphaphathehi ba aha matlo moo ba tla dula teng.

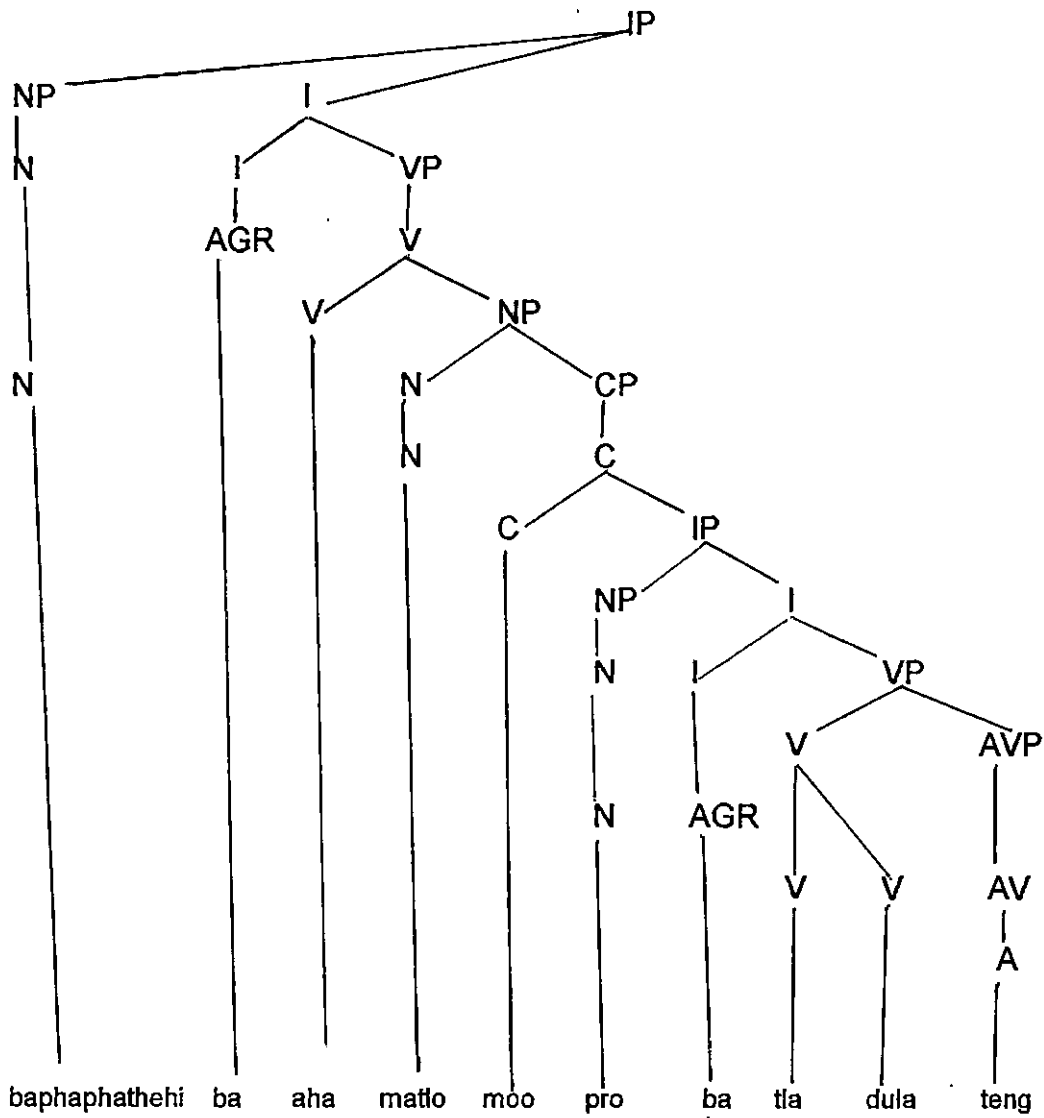

Sentence 54 is bad because the enclitic -ng is attached to the verb dula to make it dulang.

5.3 CONCLUSION

We have observed that a preposition is a proper governor in GB. In GB both prepositional and adverbial phrases can modify the verbal heads. There is also the possibility that an empty category can be substituted by the resumptive pronoun at non-syntactic level in Sesotho. But it must be clear that the very same position which can be occupied by the resumptive pronoun is an argument position and in this way the theta-criterion is in no other way violated.

BIBLIOGRAPHY

1. Adum, J. 1955. A grammar of anaphora. MIT Press, Cambridge, Massachusetts.
2. Aoun, J. 1979. On Government, Case-marking, and Clitic placement. Ms. Massachusetts Institute of Technology.
3. Baker, M.C. 1988. Incorporation: A Theory of Grammatical Function Changing. The University of Chicago Press; London.
4. Bennis, H. And Haegeman, L. 1984. On the status of agreement and relative clauses in West-Flemish. In Sentential Complementation. Edited by W. De Geest and Y. Putseys. Foris Publications, Dordrecht.
5. Brown, E.K. and Miller, J.E. 1980. Syntax. A linguistic Introduction to Sentence Structure. Hutchinson Group: South Africa.
6. Chomsky, N. 1981. Lectures on Government and Binding. Foris, Dordrecht.
7. Cole, D.T. 1955. Introduction to Tswana Grammar. Longmans, Green and Co: London, Cape Town, New York.
8. Doke, C.M. and S.M. Mofokeng 1957. Textbook of Southern Sotho Grammar. University Press Witwatersrand, Johannesburg.
9. Doke, C.M. 1945. A textbook of Zulu Grammar. Longmans Green and Co, London.
10. Doke, C.M. 1938. Bantu Linguistic Terminology . Longmans Green and Co, London.
11. Guma, S.M. 1971. An outline structure of Southern Sotho . Shuter and Shooter, Pietermaritzburg.
12. Harlow, S. 1982. Government and relativisation in Celtic. In Binding and Filtering.

Groom Helm, London.

13. Haegeman, L. 1991. Introduction to Government and Binding Theory. Blackwell Publishers, U.S.A.
14. Higginbotham, J. 1980a. Pronouns and bound variables. In Linguistic Inquiry 11.4.
15. Jacottet, E. 1927. A grammar of the Sesuto Language. The University of the Witwatersrand Press, Johannesburg.
16. Lasnik, H and Uriagereka, J. 1988. A course in GB Syntax Lectures on Binding and Empty Categories. MIT Press, Massachusetts.
17. Lebeaux, D. 1991. Relative clauses licensing and the native of the derivation. In Syntax and semantics. Vol 25. Academic Press, USA.
18. Mangoaela, G.L. 1969. A Comparative study of the relative construction in the Nguni and Sotho Languages of Southern Africa. M.A. Dissertation University of Wisconsin.
19. Matthews, P.H. 1981. Syntax. Press Syndicate of the university of Cambridge: Cambridge, Cambridge.
20. Radford, A. 1988. Transformational Grammar. Press Syndicate of the university of Cambridge , Cambridge.
21. Rittner, K. 1995. The case of German relatives. In The Linguistics Review. Vol 12 (3).
22. Ross, J.R. 1967. Constraints on variables in syntax unpublished Ph.D Dissertation MIT, Cambridge.
23. Sells, P. 1985. Lectures on Government and binding. Cambridge Univ Press, Massachusetts.
24. Shlonsky, U. 1992. Resumptive pronouns as a last resort. In Linguistic Inquiry. Vol 23 (3) 443-468.

25. Visser, M. 1985. Aspects of the empty categories in Xhosa within the theory of Government and binding. South African Journal of African Languages.
26. Vitale, A.J. 1975. Case-Marking in a Non-ease Language: The Swahili Locative. Unpublished paper presented to the LSA Summer Meeting, Tampa: Florida.
27. Vitale, A.J. 1976. A Transformational Syntax of Swahili. University Microfilms International : England.
28. Wasow, T. 1972. Anaphoric relations in English: Doctoral dissertation, Massachusetts Institute of Technology